

Ferročrtalič | Airbus  
LTH Castings | Tesla

Kovis | Siemens  
Unior | Porsche

Akrapovič | Ducati  
Adient | Volvo

Domel | Electrolux  
Hidria | Mercedes

GoOpti | Qatar Airlines  
Pipistrel | Uber

# Discover Slovenia

November 2017



## Champions of Niche

Alfastreet Marine  
Metrel

Adria Mobil  
Iskraemeco

Revoz  
Organika +

Luka Koper  
Kolpa

Skaza

Domel

Pivka Perutnina  
Toring

Don Don  
Turbine

Krka  
Lek Robotina

**“THE BEST WAY  
TO PREDICT  
THE FUTURE  
IS TO CREATE IT.”**

*Abraham Lincoln*

**CREATE YOUR FUTURE WITH US.**

ALUMINIUM DIE-CAST AUTOMOTIVE COMPONENTS. FROM INITIAL DEVELOPMENT  
TO SERIES PRODUCTION WITH OUR OWN TOOLSHOP.

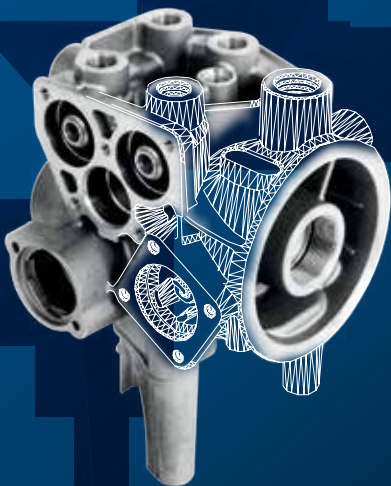

**LTH Castings**

**CASTING THE FUTURE**  
SINCE 1948

[WWW.LTHCASTINGS.COM](http://WWW.LTHCASTINGS.COM)

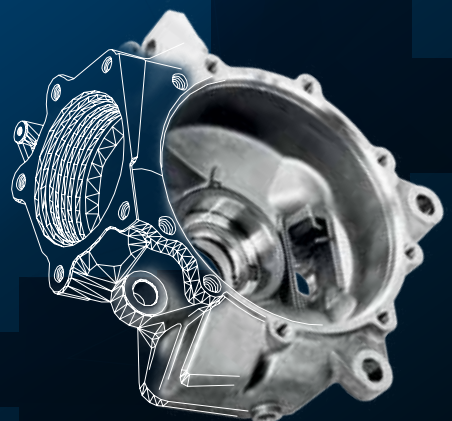

# Top New Products for Famous World Brands

**Sandiline - Adidas** **NEW**  
Technical clothing for water sports.



**Domel - Electrolux** **NEW**  
A vacuum cleaner motor that weighs less than 500 grams.



**Cleangrad - Pfizer** **NEW**  
New fire safety windows according to GMP standards.



**Bosio - Škoda** **NEW**  
The automatic continuous roller-heat line for heat treatment of forged parts which is able to process 24 tons of forged parts per day.



»The strength of the technologic partnership and the commercial cooperation between Akrapovič and Yamaha will last for many years.«



Eric de Seynes  
COO of Yamaha Motor Europe

**Akrapovič - Yamaha** **NEW**  
An exhaust system for the Yamaha YXZ100R four-wheeler.



**Iskra - Alstom** **NEW**  
The new Class A accuracy certified power quality analyzer iMC784.



**Kovis - Siemens** **NEW**  
A special brake disc for the latest Siemens ICE 3 generation of rapid trains to be used by the Deutsche Bahn.

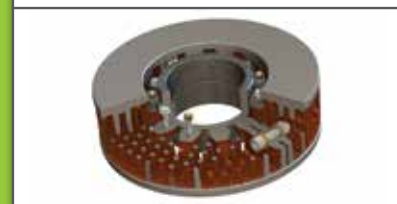

»Our partnership with Comtrade was fundamental to turning myRyanair from a vision to a reality.«



John Hurley,  
Chief Technology Officer,  
Ryanair

**Mikropis - E-mart** **NEW**  
Self-Checkout Cashiers in several supermarkets in South Korea.



**Talum - KTM** **NEW**  
Motorcycle subframes for seats and oil pan cover.



**Kovinoplastika Lož - Nobilia** **NEW**  
Alveus kitchen sinks and mixer taps for renowned Nobilia kitchens.



**Turna - Gaggenau** **NEW**  
High quality hinges for soft opening and closing of oven doors in the product segment of appliances that weigh over 20 kilograms.



»As a top quality manufacturer of cookware we need suppliers with high standards like Talum.«



Dr. Peter Schätzler  
Director Supply Chain  
Management, Fissler  
GmbH

# THE MORE YOU TRAVEL, THE MORE YOU BENEFIT



NEW AND IMPROVED

## ADRIA CORPORATE PROGRAMME (ACP)

In addition to collecting flight points benefits, ACP allows you to check-in at the business passengers' point and fast access through security control point at the Ljubljana Airport.

For more info about ACP, please go to [www.adria.si/en/acp](http://www.adria.si/en/acp).

Companies that often travel with us can also become members of the exclusive ACP+ programme with special discounts and additional benefits.

More info about ACP+ on demand at [sales@adria.si](mailto:sales@adria.si).



# Perfection in luxury interior



**METS** MARINE EQUIPMENT  
**TRADE** TRADE SHOW  
14-15-16 NOV 2017  
AMSTERDAM



[www.bobic.eu](http://www.bobic.eu) | [info@bobic.eu](mailto:info@bobic.eu)

**YACHT INTERIOR**  
**BOBIČ**  
*Since 1960*

# Discover Slovenia

November 2017

## Published by:

Chamber of Commerce and Industry  
of Slovenia  
Dimičeva 13, SI-1504 Ljubljana, Slovenia



## Editor in Chief:

Goran Novković

## Executive Editor:

Barbara Perko

## Design and Layout:

Samo Grčman

## Editorial Board:

Grit Ackermann, Ariana Grobelnik,  
Bojan Ivanc, Igor Knez,  
Tomaž Kordiš, Janja Leban,  
Ante Milevoj, Tajda Pelicon,  
Petra Prebil Bašin, Igor Zorko

## Editorial Office:

Dimičeva 13, SI-1504 Ljubljana, Slovenia  
+386 1 5898 000  
gg.plus@gzs.si

## Advertising Sales:

Dašis, d.o.o.  
gg.trzenje@gzs.si  
01 5130 824

Printed by: Present, d. o. o.

Published on: 6 November 2017

Distributed by: Pošta Slovenije

Discover Slovenia is a special edition  
of Glas Gospodarstva.

Glas Gospodarstva is published by the Chamber  
of Commerce and Industry of Slovenia, Dimičeva  
13, Ljubljana, Slovenia. It is entered into the mass  
media register held by Slovenia's Ministry of  
Education, Science and Sport, under the serial  
number 516.

ISSN 13183672

This magazine is printed on the recycled paper  
Viprint by VIPAP VIDEM KRŠKO, d. d., which has  
obtained the FSC® Certificate for the whole range  
of their paper grades, and the European Ecolabel  
(flower logo) for some of their products from the  
product group of copying and graphic paper.

Environmentally-friendly vegetable-based inks  
were used in printing.

Cover photo: Profimedia



**A Story Of Success**

9



**Best innovators of 2017**

122

## Editorial

Hidden and Visible Champions

5

## Overview

Slovenia

6

## Success Story

Slovenia - A European Star

9

## Slovenia's Demography

Increasingly Educated Structure of the Population

12

## Economic Overview

Current GDP Growth Twice as Fast as in the Eurozone

15

## Sectors and Regions

Economic Picture of Regions and Activities

18

## Top Slovene Business Linked Data

Top Business Linked Data

24

## Advantages

Why Do Business in Slovenia?

26

## Making Your Business in Slovenia

First Steps in Setting Up a Business in Slovenia

29

## CCIS

The Chamber's Recipe: Contact + IRD Input = contRact

32

## Champions

Slovene Basketball Team's Winning Spirit – Modesty & Passion

36

## Top Slovene Brands & Products

42-101

## Top Exporters

Companies Generating Two-Thirds of Slovene Exports

104

List of 200 Largest Companies by Exports in 2016

105

List of 100 Fastest Growing Companies by Exports in the Period 2012-2016

115

## Best Innovators of 2017

»The Future Belongs to Those Who Believe in Dreams.«

122

## Africa

Environmental Projects in South Africa

132

## Startup Companies

A Cryptocurrency Offering Raises 10 Million Dollars in Less  
Than 5 Minutes

136

## Exceptional

Slovene Products Taking Your Breath Away

140

## Promotion

Slovenia – Your Next Filming Location?

146

## Index

153

## Hidden and Visible Champions

When Slovenia gained independence in 1991, few Slovenes imagined that the Slovene basketball team would ever be the winner of the European championship. This year they made it. And hardly anyone believed that the handball and volleyball national teams would ever be second in Europe. Nevertheless, they both made it.

Likely fewer believed that the national football team would ever qualify for large competitions; yet they did, three times, twice to the World and once to the European championship. Slovenia is among the smaller countries to ever qualify for the largest sports competition in the world, which the World Cup definitively is.

In 1991, the Slovenes were convinced that our athletes could only be successful in niche sports, such as alpine skiing, ski jumping, cross-country skiing, snowboarding, rowing, kayaking, sailing, maybe athletics, judo, shooting ... That Slovenes can exceed expectations has been confirmed at a number of the European and World championships, including the Olympic Games. Considering its population, Slovenia has been among the most successful countries at the Olympic Games.

We can identify at least two significant similarities between Slovene athletes and export companies. As Slovene athletes initially gained success in the less visible, niche sports, so did businesses in this country in the 1990s sell goods and services in the amount of 5 billion euros, substantially less than today. And as sports triumphs became ever more visible, so did Slovene exporters. Export in 2016 amounted to as much as 33 billion euros.

However, it is true that the Slovene companies are more hidden from the eyes of the general public than this country's athletes. Slovenia does not produce a lot of known end consumer products that display the name of a global brand. Some can be found in pharmaceuticals, sports equipment, household appliances ... But Slovenia does manufacture a lot of products and services which comprise important parts of the most prestigious global brands, including some that world multinationals developed with the assistance of Slovene know-how in their companies located in our country.

If not for a number of Slovene companies being competitive, we would not – after the global crises from 2008 to 2013 – be witnessing such a renaissance of this country's economy. The annual growth of GDP in a range of more than four percent also allows a considerably faster development of infrastructure. Large investments are already being made in logistics, in aspects that are being considerably modernised. This will additionally connect the export-oriented Slovene economy with the world.







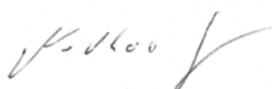

Slovenia has visible and hidden champions. What is even more important is that most Slovene companies ambitiously seek hidden and visible champions abroad in order to establish partnership cooperation in the development of new products. They hold niche know-know, which is borne out by this year's edition of the magazine Discover Slovenia – Champions of Niche.

Last year's edition illustrated the magnitude of the Slovene products inbuilt in global brands. More than 170 strong connections with world renowned brands were shown. In this year's magazine, which you are just leafing through, we have focused on their new and future products. They can be found in brands such as Audi, BMW, Gaggenau, Panasonic, Bombardier, Kärcher, Electrolux, Alstom, Deutsche Telekom, Adidas, Prada, etc.

We are confident that this magazine will provide you a lot of useful information. Possibly soon a new business partner from Slovenia. You are most welcome.

Goran Novković, Editor in Chief



	<b>Sustainable Mobility</b> 42
	<b>Intelligent Home</b> 50
	<b>Health and Wellbeing</b> 58
	<b>Special Materials</b> 76
	<b>Smart Electronics</b> 82
	<b>Strategic Logistics</b> 88
	<b>Contemporary IT</b> 96
	<b>Champions of Niche</b> 100
	<b>The Hottest Innovations</b> 122

Printed on the recycled paper Vprint, 80 g, by VPPAP VIDEMARŠKO, d. d.

# Slovenia

**Official name:** Republic of Slovenia  
**Capital city:** Ljubljana  
**Government:** Parliamentary Republic  
**State President:** Borut Pahor  
**Prime Minister:** Miro Cerar  
**Local government:** 212 municipalities, of which 11 have urban status; 12 statistical regions, which are grouped into two cohesion regions – Western and Eastern Slovenia  
**Area:** 20,273 km<sup>2</sup>  
**Population:** 2,065,895 (1 January 2017)  
**Location:** bordered by Austria, Italy, Hungary and Croatia; excellent connections with all European markets  
**Currency:** Euro  
**GDP per capita:** 19,576 euros  
**Projected growth for 2018:** 3.3%  
(Eastern European Consensus Forecasts)  
**Time zone:** CET (GMT+1), and CEST (GMT+2) in summer  
**Official languages:** Slovene, together with Italian and Hungarian, respectively in the areas with Italian and Hungarian minorities.

Source: Statistical Office of Republic of Slovenia



Photo: Depositphotos

Printed on the recycled paper Viprint, 80 g, by VIP&P WIDEMKRSNO, d. d.

Official gateway to information on Slovenia.

A square QR code with a black and white pixelated pattern, located below the text in a green-bordered box.

Photo: Depositphotos



**TRANSFORMER  
STATIONS, MINSK,  
BELARUS**

**THE P.A.T.H. HOUSE  
BY STARCK WITH  
RIKO**



**SVETA PETKA  
HYDROELECTRIC  
POWER PLANT,  
SKOPJE, MACEDONIA**

**WOODEN  
KINDERGARTEN,  
MINSK**

## **GLOBAL ENGINEERING FOR SLOVENIAN EXPORT**

**RIKO CONNECTS SLOVENIAN COMPANIES FOR A PROPULSIVE  
ENTRANCE INTO THE MOST DEMANDING ENVIRONMENTS.**

We connect the best companies, their technological skills, solutions and products into new achievements of joint excellence through prestigious projects. Success is always holistic – also because we support art and culture as well as other values that enrich life in Riko's environments.



## **WELDS TOGETHER WHAT BELONGS TOGETHER – YOU AND YOUR CUSTOMERS**

If you value the quality of your products, use welding robots from the MOTOMAN MA series. Your customers will reward you for it with their loyalty. If the robotic welding is good, the product will be good – and your customer satisfied.

# Slovenia - A European Star

The highest growth rate in a decade remains well balanced.

Bojan Ivanc

Slovenia's economy has been recovering well over the past two years. Indeed, economic growth in the last quarter was at its highest level since 2008, while annualised seasonally adjusted quarterly GDP growth currently stands at 5.2 percent. This growth is 1.25 times higher than the eurozone average (2.3 percent) and the third highest in the EU-28 (behind the Republic of Ireland and Romania). This growth is primarily a consequence of household consumption, although the measure is still below the pre-financial-crisis level. GFCF (Gross fixed capital formation) also grew by 4.7 percent.

According to current forecasts, economic growth in Slovenia is anticipated to be 4.4 percent in 2017, declining to 3.3 percent in 2018. However, growth is quite likely to be higher due to a favourable export cycle into the major European markets and the continuing low interest rates that are stimulating vehicle and real estate purchases. Slovenia's upcoming general election is also anticipated to strengthen major investments, as well as engender higher levels of state spending.

## Trade balance (goods & services)

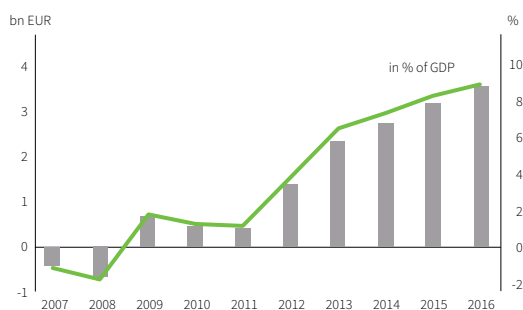

## Exports Increasing at Twice the EU Average

Some three-quarters of Slovenia's trade is with other EU states, and represents over 80 percent of GDP. Actual exports increased by 8 percent over the past 12 months, twice the eurozone and EU-28 average. In the first six months of 2017, service sector exports were up 12 percent, mostly as a consequence of rises in transport and tourism revenues, together with new foreign contracts for Slovene construction enterprises.

Slovene companies have strengthened their balance sheets and undergone structural transformation over the past decade. The averaged net

debt ratio (net interest-bearing debt to EBITDA ratio) dropped from 6 times to less than 3, while monetary assets represent some 5.6 percent of total active assets. Value added per employee exceeded 42,000 EUR, which is mainly due to the lower prices of raw materials used by Slovene exporters. Return on equity increased to almost 8 percent in 2016, while companies reinvested 5 percent of sales revenues. Investment activities, which have lagged behind the long-term average by more than a percentage point over recent years, are anticipated to grow.

## Current account balance

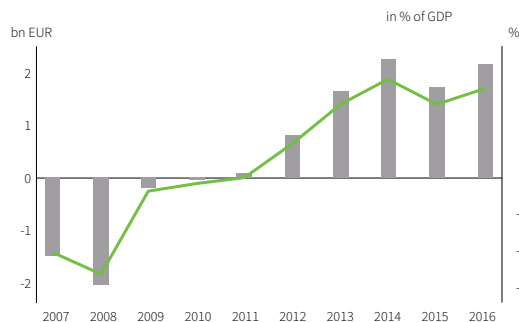

## Awakening Consumers

Lagging some 24 months behind the curve of the EU average, household spending in Slovenia is now recovering, and this is for the most part a consequence of a more dynamic labour market. Excluding self-employed farmers, the active labour force is 3.3

Above  
**4 %**  
annual growth  
in 2017.



Photo: Depositphotos

**FDI (stock)**

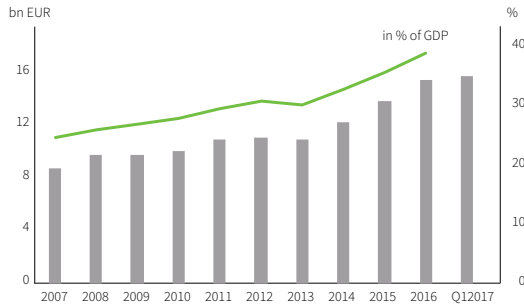

Labour productivity has risen from **34** thousand to **42** thousand euros per capita per annum in a decade.

percent greater (June 2017 interim), with most sectors experiencing growth. Hiring through recruitment agencies is again on the increase, as is the hiring of foreign nationals, consequent to the rapid growth in construction. Although many companies are increasingly pointing to the problems they face in relation to hiring suitable labour, there are plans for considerable recruitment over the coming months. The survey unemployment rate (ILO) dropped to 7 percent, which is 2 percentage points below the eurozone average. The pre-crisis unemployment rate was 4 percent, and stood at 11 percent at the beginning of the year.

Unemployment has fallen to **7** percent.

Average gross monthly salaries were some 0.3 percent higher in real terms across the first half of 2017, while actual net salaries were 0.6 percent higher primarily consequent to wage growth among lower earners (labour cost relief, which came into force in January). The growth in household consumption is mostly due to increased employment figures, a reduction in cash reserves and credit growth. Consumer (household) debt has risen by 12 percent year on, while mortgage lending was up by 5 percent.

This increase in consumer and household debt is not considered excessive. Real estate prices have only been rising in the past two years, and were up by an average of 4 percent over the last 12 months, a rate below the EU-28 average (+ 4.5 percent). Household debt is also below the European mean, and is equivalent to some six-months income (the eurozone average household debt is equivalent to some 11 months income).

**GDP per capita**

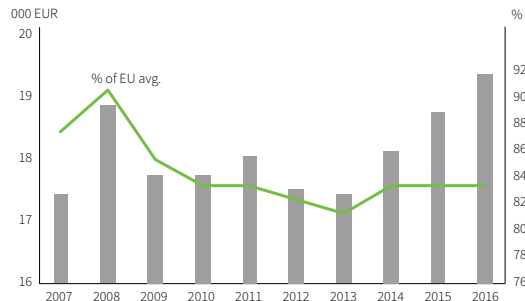

**Successful Reduction of Deficit**

Slovenia's budget deficit has been reducing faster than anticipated. According to the most recent estimations by the Ministry of Finance, the deficit in

**R&D expenditure (million EUR)**

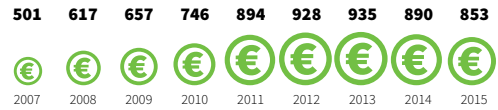

2017 will be some 279 million euros (equivalent to 0.7 percent of GDP), which is 60 percent lower than the 2016 budget forecast. The reduction in the shortfall is due to higher tax revenues, which is a consequence of higher consumer spending.

Despite the strong upturn in domestic business cycle, inflation remains low. In the 12 months prior to July 2017 prices grew by 1.1 percent, which is less than the eurozone average (1.2 percent). Strong demand for labour, however, could engender increases in salaries and consequently prices over the coming months.

**GDP growth**

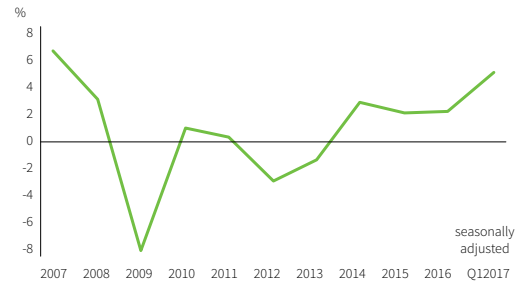

The main risk for the Slovene economy is a possible downward drift in the erstwhile favourable export trends, the unknown timeframe necessary for transition away from diesel vehicles to electro-mobility as well as political uncertainties pertaining to Europe's single market and the Schengen zone in particular.

Being a small open economy, the single market and the four freedoms prescribed by EU - free movement of goods, services, labour and capital - are of crucial importance for Slovenia's export-oriented economy.

**Ranking**

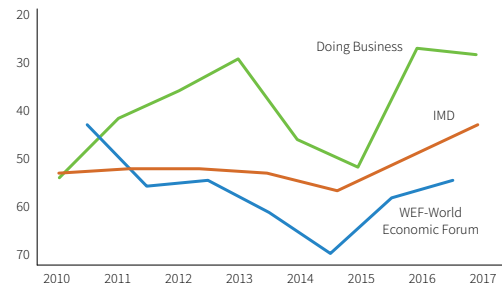

Sources: Bank of Slovenia, Statistical Office of Republic of Slovenia, Doing Business, IMD - World Competitiveness Rankings, WEF - The Global World Competitiveness Report



**Mobility  
Components & Systems**



**Power Engineering**



**Engineering &  
Technology Systems**

**KOLEKTOR**

[www.kolektor.com](http://www.kolektor.com)

# Increasingly Educated Structure of the Population

**Graduates with an education in natural sciences or technology are the profile most sought after on the labour market.**

*Bojan Ivanc*

In Slovenia, approximately 300,000, or 15 percent of the population, are less than 14 years old. Some 390,000 are over 65. The largest number is between 30 and 40 years old. In accordance with demographic projections, the older share of the population will increase, and the solution to a decreasing labour force will be the extension of working years, faster inclusion of the population into the labour force, and the import of workers in areas where there are shortfalls.

Of the approximately 2.07 million strong Slovene population, 95 percent are citizens, and 5 percent are foreigners.

## Inhabitants



Citizens of Slovenia **1,951,457**

Foreign citizens **114,438**

The educational level of the population older than 14 years is good and on an upward trend. Twenty-two percent of this population has university diploma, and 30 percent has post-secondary education. 21 percent have at least a vocational degree. Mainly people in the age group between 25 to 44 years have a tertiary education. Graduates with an education in natural sciences or technology are the profile most sought after on the labour market, while there is a sufficient amount of graduates in economics, law, and social sciences.

## Education by age groups

Age	Total	Basic or less	Upper secondary	Tertiary
as of total	1,757,798	443,608	925,832	388,358
	100%	25%	53%	22%
15-19 years	94,654	79,145	15,509	0
20-24 years	104,500	12,186	77,722	14,592
25-29 years	128,172	9,140	72,514	46,518
30-34 years	145,305	10,886	79,611	54,808
35-39 years	157,505	13,731	87,331	56,443
40-44 years	150,102	18,618	84,377	47,107
45-49 years	149,386	25,150	86,177	38,059
50-54 years	154,542	27,659	93,316	33,567
55-59 years	149,432	37,399	84,385	27,648
60-64 years	144,098	46,240	75,582	22,276
65 + years	380,102	163,454	169,308	47,340

## Age structure of employees

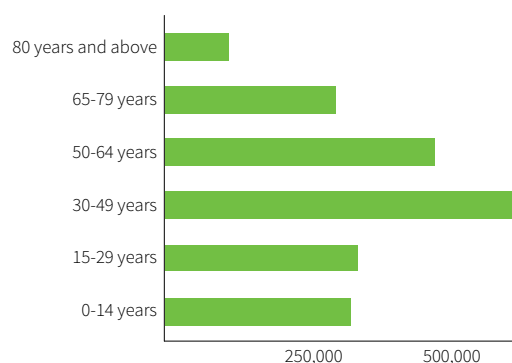

Source: Statistical Office of Republic of Slovenia

# DESIGNED FOR LIVING. ALL-NEW XLINE.



# DESIGNED FOR GLAMPING. ALL-NEW SAFARI LOFT.



# GLAMPING PARADISE. BOUTIQUE.



Adria is the most professional **'one stop shop'** for camping resort operators offering distinctive and unique holiday experiences to customers. No-one else can offer such a full service, from standardized and custom mobile home and mobile tent manufacturing right through to after sales warranty and service. We are upgrading glamping business in order for your success.

**Adria Home L.T.D.**

Kanižarica 41 • SI-8340 Črnomelj • Slovenia  
Tel: +386 (0) 7 35 69 100 • Fax: +386 (0) 7 35 69 105  
Email: [info@adria-mobilehome.com](mailto:info@adria-mobilehome.com)  
[www.facebook.com/adria.mobilehome/](https://www.facebook.com/adria.mobilehome/)

[www.adria-mobilehome.com](http://www.adria-mobilehome.com)



**TPV GROUP**  
CORPORATION

Providing mobility of the future

## **AUTOMOTIVE INDUSTRY**



We are one of the leading development suppliers in the automotive industry. We develop and produce lightweight products that ensure comfort, safety and efficiency for the most demanding car manufacturers.

We develop and produce a wide range of light transport trailers in cooperation with our partner Bockmann. We are one of the leading light transport trailer manufacturers in Europe.



## **LIGHT TRANSPORT TRAILERS**

We offer effective and simple automation solutions for internal logistics based on our extensive knowledge of the requirements of industrial material handling. We have developed our own super low AGV TPV Optimatik 160.



## **COMPLETE INTERNAL LOGISTICS SOLUTIONS with AGV**

[www.tpv.si](http://www.tpv.si)

Kandijska c. 60, SI-8000 Novo mesto, Slovenia  
Tel: +386 7 39 18 100, [tpv@tpv.si](mailto:tpv@tpv.si)

Connecting innovative solutions



# Current GDP Growth Twice as Fast as in the Eurozone

**Above average growth due to rising investment and domestic consumption will continue until at least 2018.**

*Bojan Ivanc*

Slovene GDP has been increasing since the last quarter of 2013. In the period from 2014 to 2016, it has been growing between 2 and 3 percent. In the first half of 2017, growth exceeded 5 percent, a result of an uptick in household consumption, growth in investment, and exceptionally favourable conditions for exports. In terms of development compared to the EU-28 average, Slovenia has regressed since 2013, the consequence of the eurozone economic crisis, the restructuring of the banking sector, and the excessive indebtedness of the corporate sector.

## GDP growth rate

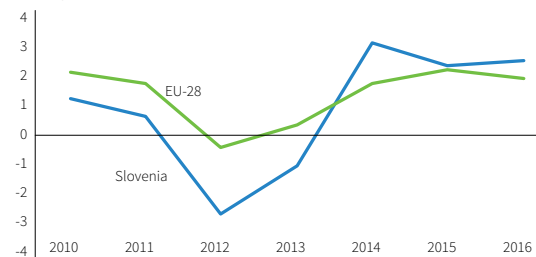

Sources: Statistical Office of Republic of Slovenia, Doing Business, IMD - World Competitiveness Rankings, WEF - The Global World Competitiveness Report

Slovenia's trade balance for goods and services became positive after 2009, a consequence of reduced imports of goods for investment in the construction industry as well as higher demand for Slovene goods and services, the latter being the result of an improvement in labour cost competitiveness. The current account surplus of the balance of payments was somewhat lower than the surplus for goods and services, primarily because of the higher payouts of dividends to foreign owners.

The level of foreign direct investment (FDI) in the first quarter of 2017 rose to 15 billion euros, representing 38 percent of GDP.

Last year Slovenia advanced on the Doing Business ranking after substantial declines through 2015. It saw significant advances in the following segments: tax collection, registration of real estate, and registration of expenses related to insolvency. Progress on the IMD ranking was somewhat weaker with Slovenia occupying 43<sup>rd</sup> place out of 60 countries. On the WEF ranking, Slovenia occupies 56<sup>th</sup> place out of 138 countries, similar to its ranking in 2012. It enjoys highest rankings in health, primary and higher education, as well as innovation.

**PRODUCT RANGE**

- Antioxidants for health and well-being
- Tannins for enhancing wines and cognacs
- Animal food
- Leather goods
- Textiles
- Energy
- Petrochemicals

**25**  
years.  
openminds.

**STUDIO  
MODERNA**

**REGION'S LEADING MULTI-BRAND AND OMNI-CHANNEL RETAILER**

- Successfully operating across **21 countries**
- Addressing **360 MIO** consumers across Europe & beyond
- Broadcasting more than **240 h/day**, on more than **360** major channels
- **360 DORMEO HOME** and **TOP SHOP** stores reinforcing the brand experience
- selling products throughout many established networks
- **33 call centers**: serving more than **10 MIO** inbound calls/year & **70 MIO** outbound calls/year
- major online presence through **140** local websites; launching more than **70** e-mail campaigns/week
- **100** different catalogues/year and over **20 MIO** copies in total
- **18 MIO** customer database

»Wherever the customer is, however he wants to buy, our aim is to be there.«

Our brands also enjoy global success in markets such as USA, Canada, UK and Japan.

**TOP SHOP** 

**DORMEO**

**delimano**

**KOSMODISK**

**PINK  
PANDA**

**WALKMAXX**

**ROVUS**

**wellneo**

**Mango**

# HRASTNIK 1860

GLOBAL PARTNER IN THE DEVELOPMENT  
OF PREMIUM GLASS PRODUCTS

[www.hrastnik1860.com](http://www.hrastnik1860.com)

**High**  
Glass  
SPIRITS



# Economic Picture of Regions and Activities

**The growth of foreign investment strengthens Slovenia's potential for development.**

*Bojan Ivanc*

**The Central Slovenia region produces more than one third of GDP.**

Slovenia is divided into two main regions: East and West, each of which exhibits different levels of economic growth. In the western region, GDP per capita is one-fifth higher than the national average, while in the eastern region it is one-sixth lower. Fifty-three percent of the population lives in the eastern region, which generates 17 billion euros or 44 percent of total GDP. The level of unemployment in the east is somewhat higher, since 60 percent of the total number of unemployed lives in that region.

Slovenia is also divided into 12 statistical regions that differ in terms of economic development. Four regions fall into the broader western region, while the remaining eight are in the east. The distribution of GDP per region is connected to where the headquarters of companies are located. For this reason, the economic importance of the central Slovene region is somewhat overestimated, since many companies are headquartered in Ljubljana, while the production and marketing departments may be located in other regions.

The Central Slovenia region generates 37 percent of GDP, followed by the Podravska region (13 percent),

and Koroška (11 percent). The Zasavska region, accounting for 1.5 percent of GDP, is the smallest in economic terms as well as has the lowest standard of living (10,000 euros per capita), half of the national average.

**Statistical regions by GDP p.c.**

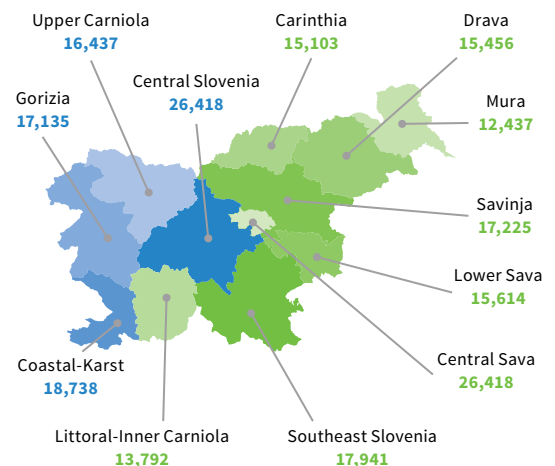

Statistical region	GDP p.c.	Hourly labour costs	Hourly net earnings	Regional capital	Nb. of inhabitants	Average age	Employed	Unemployed
<b>SLOVENIA</b>	<b>18,693</b>	<b>11.0</b>	<b>6.1</b>		<b>2,065,895</b>	<b>43.0</b>	<b>827,596</b>	<b>114,222</b>
<b>Eastern region</b>	<b>15,493</b>	<b>10.1</b>	<b>5.7</b>		<b>1,091,159</b>		<b>431,959</b>	<b>68,245</b>
Mura	12,437	9.7	5.6	Murska Sobota	115,477	44.7	43,782	9,549
Drava	15,456	10.1	5.7	Maribor	322,043	43.8	126,599	19,117
Carinthia	15,103	10.3	5.8	Slovenj Gradec	70,761	43.7	28,907	3,566
Savinja	17,225	10.1	5.7	Celje	254,761	42.9	101,565	15,843
Central Sava	10,060	9.8	5.6	Trbovlje	57,280	44.0	22,184	3,859
Lower Sava	15,614	10.2	5.8	Krško	75,544	43.6	29,679	4,873
Southeast Slovenia	17,941	10.9	6.1	Novo Mesto	142,711	42.2	57,656	8,723
Littoral-Inner Carniola	13,792	9.6	5.5	Postojna	52,582	43.3	21,587	2,715
<b>Western region</b>	<b>22,296</b>	<b>11.1</b>	<b>6.2</b>		<b>974,736</b>		<b>395,637</b>	<b>45,977</b>
Central Slovenia	26,418	12.1	6.7	Ljubljana	539,672	41.6	218,454	27,200
Upper Carniola	16,437	10.8	6.1	Kranj	203,800	42.6	84,232	7,898
Gorizia	17,135	10.6	6.0	Gorica	117,747	44.4	47,368	5,084
Coastal-Karst	18,738	10.9	6.1	Koper	113,517	44.2	45,583	5,795

as of 2015

as of 1H 2017

as of 1H 2017

as of 2016

as of 2016

The level of economic development in various regions can also be explained by differences in the hourly labour costs. These differences are lower than in the GDP, due to the different structure of activities per region and labour legislation or the minimum wage mechanism. The lowest hourly rate is in Pomurje, where it is 9.7 euros per hour, more than a tenth lower than the national average. The Central Slovenia region is the only region where average hourly wages are above the national average, at 12 euros per hour.

The average age of the population is the highest in Pomurje (44.7 years), the lowest in the Central Slovenia region (41.6 years). This is in part a consequence of the fact that Ljubljana is an important university centre for the neighbouring regions.

### Manufacturing Industry is Growing

The economic activity that has the greatest value added in Slovenia is the manufacturing industry, namely 7.7 billion euros, or 23 percent of the total. It is followed by retail with a 12 percent share, and real estate with 7 percent.

In the last eight years, the manufacturing industry's share has continued to grow, mostly because of improvement in export competitiveness, while the share of retail has fallen. It is anticipated that the retail segment will begin growing again after 2016 because of easing consumption patterns during the period from 2009 to 2013, growth in salaries, and falling interest rates.

Because the labour productivity in manufacturing industry is higher than in retail, the share of employment in retail is 15.4 percent, and 21 percent in the manufacturing industry. The hourly rate per employee is highest in the financial industry (55

**The lowest hourly wage is earned in Pomurje.**

**More growth in value added in the retail sector is expected.**

### Top 12 sectors by value added (million EUR)



	Value added (million EUR)	As of total (%)	Nb. of employees (000)	Total hourly labour costs per employee	As of average (%)
C Manufacturing	7,738	23.2%	197.0	14.4	97.7%
G Wholesale and retail trade, repair of motor vehicles and motorcycles	3,959	11.9%	117.1	14.1	95.3%
L Real estate activities	2,306	6.9%	5.5	13.1	89.1%
M Professional, scientific and technical activities	2,284	6.9%	73.7	16.8	114.2%
H Transportation and storage	2,073	6.2%	50.7	14.0	94.8%
O Public administration and defence, compulsory social security	1,953	5.9%	49.5	17.5	118.6%
P Education	1,828	5.5%	70.5	16.7	113.4%
F Construction	1,826	5.5%	62.1	10.7	72.4%
Q Human health and social work activities	1,716	5.2%	61.8	15.2	102.8%
J Information and communication	1,395	4.2%	28.5	20.6	139.6%
K Financial and insurance activities	1,388	4.2%	22.3	22.7	154.1%
N Administrative and support service activities	1,035	3.1%	51.1	10.4	70.8%
D Electricity, gas, steam and air conditioning supply	890	2.7%	9.0	21.1	143.4%
A Agriculture, forestry and fishing	794	2.4%	74.7	13.7	92.6%
I Accommodation and food service activities	770	2.3%	37.6	9.7	66.1%
R Arts, entertainment and recreation	496	1.5%	17.6	14.3	96.9%
S Other service activities	379	1.1%	18.6	11.6	78.7%
E Water supply, sewerage, waste management and remediation activities	327	1.0%	9.4	15.3	103.9%
B Mining and quarrying	127	0.4%	2.5	21.3	144.2%

**Top sectors of FDI by value of FDI (million EUR)**

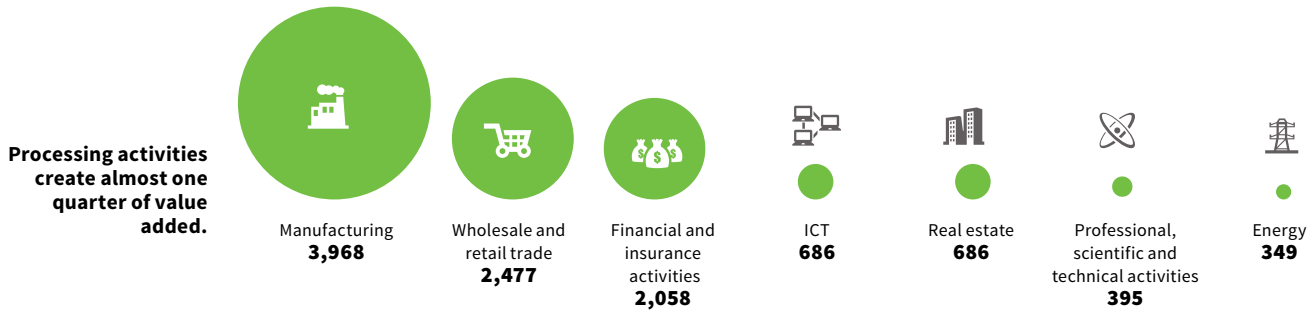

percent more), mining (44 percent more), and energy (43 percent). It is lowest in construction (10.7 euros), and administrative services and support.

**An Upward Trend in Foreign Investment**

At the end of 2015, the value of foreign direct investment (FDI) stood at 11.6 billion euros, which was 30 percent of GDP. In the first half of the fiscal year 2017, it appears that that amount will grow by nearly 2 billion euros for the full year, which is mostly the consequence of changes in the ownership of several large Slovene companies.

The most important foreign investor is Austria, which accounts for 31 percent of total FDI. The Swiss follow with 11 percent and Germany with 9 percent. In this calculation, it should be noted that Germans actually have a higher, and Austrian a lower share, because many of the Austrian investors are owned by German companies. Looking at the total value of FDI, which is comprised of foreign capital invested in Slovene companies and loans from parent companies, foreign investors are most present in the manufacturing industry (34 percent), retail (21 percent), and finance (18 percent).

**FDI stock**

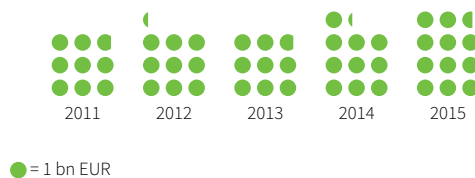

**TOP countries of origin (%)**

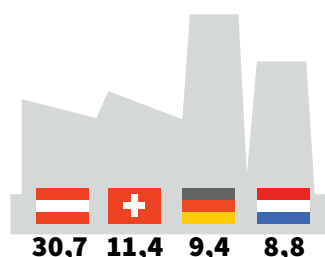

**2.2 billion euros cash inflow from tourism.**

**Germany Remains Slovenia's Most Important Trading Partner**

Slovenia exports the highest amount of goods to Germany, 20 percent, followed by the three neighbouring countries: Italy, Croatia, and Austria (27 percent all together), and France with 4.7 percent. In recent years, the importance of EU markets for Slovene exporters has risen to almost 78 percent, a consequence of economic growth in the EU-28 markets.

On the import side, the rankings of Slovenia's trade partners are similar. Austria is one place higher with a larger share (11 percent), and Hungary also has a better position. With these two countries and Italy, Slovenia recorded the highest deficit in trade in goods, in part a consequence of its placement in the value chain. These countries import raw materials, which are then incorporated into semi-finished and finished goods, and are then exported to more demanding markets. Slovenia has the largest surplus with Germany and Croatia, with about half a billion euros with each.

Slovenia's main export products are road vehicles and automotive sub-components, accounting for 15 percent of total exports, followed by pharmaceutical products, 10 percent, which is the output of two manufacturers of generic drug. Exports of electrical equipment and appliances have a similar proportion of the total. The target customers for Slovene products are therefore large car manufacturers, consumers of medicines and household appliances, and also a number of key industries that require top-quality processing and processing machines for their manufacturing work.

**In Addition to Tourism and Transport, ICT Is Also Growing**

Traditionally the largest surplus is generated by inflows from tourist activities (2.2 billion euros), followed by the transport sector, which provides services to foreign customers (1.9 billion euros) and saw a substantial increase after 2009. Exports in other types of services, such as technical and ICT services, are also growing.

**TOP 10 export products (year 2016, million EUR)**

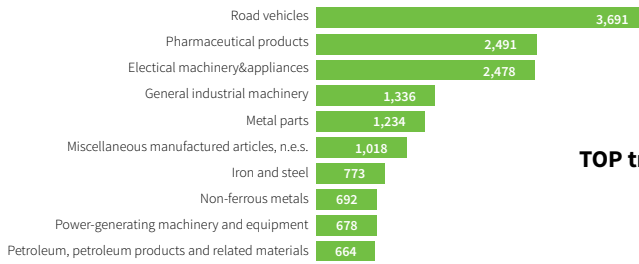

**78%**  
of exports sold in EU  
markets.

**TOP 5 export services (million EUR)**

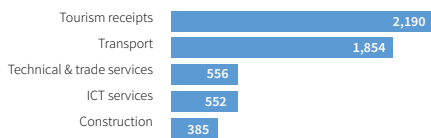

**TOP trade partners (million EUR)**

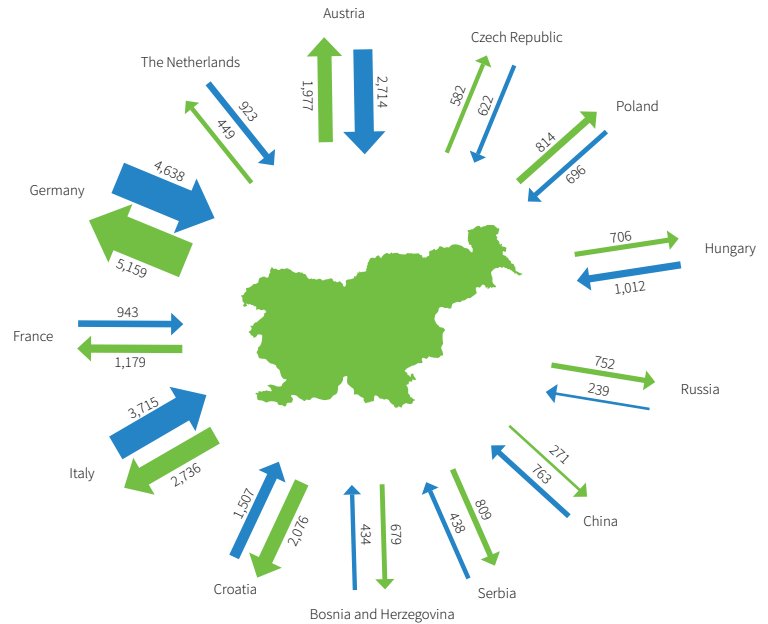

Sources: Bank of Slovenia, Statistical Office of Republic of Slovenia



**Our products are built into every second car in the world.**

A **system supplier** for the electronics and automotive industries offering integrated solutions with 3D prototypes. **Meeting the auto industry's** most demanding quality standards. **Recognition awards** for outstanding business practice. **Stable** annual average sales growth, +10%. **Developing complex tools** from the highest quality materials. **Excellent tool** properties adjusted to meet customer needs. **1000 tools** manufactured to date.



# Shot-blasting machine expert

**STEM d.o.o. company has 28 years' experience in shot-blasting technology with the unique aim of developing and producing shot-blasting machines that offer top-quality surface treatment solutions (cleaning, matting, shot-peening, stress-peening, roughening, etc.).**

STEM are based in Nova Gorica, where the shot-blasting machines are designed and produced. In addition to having its head office and production facility in Nova Gorica, STEM also has two other production plants manufacturing standard smaller machines and machines of largest dimensions.



The company's guiding principle is the continuous pursuit of the technical and technological demands of the market in order to achieve the highest quality of treated surfaces, along with efficient power consumption and cost-effective investment. STEM manufactures shot-blasting machines of various standard types and dimensions, and also in the production of special-purpose shot-blasting machines capable of meeting the requirements of the most demanding customers.

The company's global reputation derives from its turbine shot-blasting machines, used for the most

challenging work processes. STEM provides special machinery for the automotive and aircraft industries, as well as the most technologically demanding peening processes.

Some of the world's most prestigious companies – including ABB, Voith, Siemens, Škoda Auto, Linde, Bobcat and Mahle – use custom-made STEM shot-blasting machines. Škoda's vehicle production lines have more than 20 STEM sand-blasting machines, while Russia's largest railway carriage wagon manufacturer has 10. The list of users and applications is indeed extensive.

STEM will continue to pursue the objective it has set itself: to produce shot-blasting machines of the highest quality and to advance the technology in order to further improve them .

The company will continue to develop machines and automated lines in the field of surface treatment and metal protection in all industrial branches: foundries, forging plants, the automotive industry and other metal-processing industries (pipe-production, rolling mills, production of springs, welded constructions, gas bottles, etc.)

The customer is always the centre of our attention.





# Discover ebm-papst in household appliances.

You can discover innovative solutions for household appliances at [discover.ebmpapst.com/household\\_appliances](https://discover.ebmpapst.com/household_appliances)



Did you know that up to 20 products from ebm-papst can be hidden in one single home? Whether in the dishwasher, oven hood or refrigerator, our fans and small motors can handle any “household chore” reliably, quietly, and in an energy-saving manner. **You can't see it. But you can feel it!**

## ebmpapst

The engineer's choice

# Top Business Linked Data

Ease of doing business, openness to trade, education and innovations remain the strongest pillars of success.

*Bojan Ivanc*

**1<sup>st</sup>**

(out of 190) Trading Across Borders  
(Exports and Imports)

**9<sup>th</sup>**

(out of 190)  
Protection of Investors

**24<sup>th</sup>**

(out of 137)  
Higher Education

**30<sup>th</sup>**

(out of 63) Infrastructure

**30<sup>th</sup>**

(out of 190) Doing Business

**34<sup>th</sup>**

(out of 63) IMD World Digital  
Competitiveness Ranking

**35<sup>th</sup>**

(out of 137) Innovations

**35<sup>th</sup>**

(out of 137) Technological  
Readiness

**43<sup>rd</sup>**

(out of 63) World  
Competitiveness Yearbook

**48<sup>th</sup>**

(out of 137) The Global  
Competitiveness Report

**49<sup>th</sup>**

(out of 190) Start a Business



European manufacturer  
since 1919



# EUROPEAN

**partner of excellence**

Unior is an internationally renowned company with a reputation for top expertise in the field of metalworking. With its own development, Unior has secured itself the position of a renowned supplier to the automotive industry. With an exceptional tradition of smithery and with the original design of quality tools, the company has been an ally to both amateur and professional master craftsmen. Due to its comprehensive understanding of technological processes, Unior is an excellent partner in developing solutions for automatic metalworking.

**FORGE**

---

**SPECIAL MACHINES**

---

**HAND TOOLS**

---

**TOURISM**

---

# Why Do Business in Slovenia?

**Foreign investors appreciate the excellent geostrategic location of Slovenia as well as the quality of its labour force.**

*Katarina Klepec*

According to the OECD, Slovenia is a relatively highly developed country. On the basis of competences, some well-established sales channels and numerous intangibles, a number of its sectors and industries enjoy a competitive advantage. A survey of members of the Slovenian Foreign Investors Forum reveals that 77 percent of those asked would choose Slovenia again as an investment destination. According to this survey, the main reasons underpinning investment are:

1. Quality of labour force
2. Labour costs
3. Access to know-how and technology
4. Access to, or increase in, share of the Slovene market
5. Good geographical location and communications infrastructure

Slovene enterprises tend to make very good business partners for foreign investors; according to SPIRIT Slovenia, the national public agency for entrepreneurship, they tend to exhibit the following strengths:

1. Innovativity, adaptability, openness and reliability
2. A large number of internationally recognised names and brands in many areas
3. Advanced high-tech solutions and high-quality production processes
4. Rapid pace of innovation
5. Broad ecological awareness

More information



Photo: Depositphotos

The Slovenian Foreign Investors Forum (SFIF) comprises 30 Slovene companies in foreign ownership. This group was formed with the intention of improving the business environment for all Slovene enterprises. In the most recent reporting period (2016) SFIF companies accomplished aggregate sales revenues of 5.6 billion euros, equivalent to 28% of that of all foreign-owned companies and 7% of the private sector as a whole. In total they employ more than 24,000 workers and attain a value-added per employee which is 30% above the national average for the private sector. Their aggregate investment is about 330 million euros, representing one third of total foreign investment in Slovenia. Total social contributions from salaries paid to the state in 2016 amounted to 240 million euros. Last, but by no means least, they remunerated 27 million euros in taxes on profits.

# Expert in Global Communication

Translators, technicians, engineers, designers: how could exporters ever introduce themselves without their help? In the global economy, every enterprise sooner or later faces the need to translate and edit a variety of technical and commercial documents into other languages. Based on its professional, intelligent and innovative solutions, the Star Group facilitates the success of many industrial products. Elena Doren, CEO of Star Ljubljana, explains their business approach.

**You are based in Ljubljana, Slovenia, but your network is global, isn't it?**

Thanks to our professional translators, who are selected on the basis of their linguistic competence but no less on their technical skills, as well as to our developers and longstanding experience as the provider of translations and technical documentation, the Star Group is capable of offering its services in a variety of languages through various media, indeed everything from hard copy to the Internet. Actually, as the first letter of our name suggests, we are not only providing translations, but also global IT solutions through the application of SGML/XML technologies. It is the combination of multiple competences that has made the Group what it is today.

**In what ways is Star a success story?**

Established more than 30 years ago, the Star Group enjoys a presence in more than 30 countries in Europe, Asia, the United States and South America; it has 50 branches and 850 employees. This international presence ensures the generation of numerous synergies and a formidable exchange of competences. As a pioneer in the development of Computer-Assisted Translation tools, the Star Group is today a major global translation enterprise.

**How have efficient tools contributed to your success?**

In order to remain competitive internationally, it has been necessary to develop special products such as Transit, our CAT tool retrieving matches from the translation memory of each single enterprise, and TermStar, our terminology management tool which guarantees consistency and precision, indispensable in technical fields. Star also ensures an extremely strict and efficient workflow, thus we are not only focused on the trans-

lation aspect but also on the production process as a whole, right up to the finalised document ready to be printed or edited in any type of media.

**In your view, what has made you indispensable?**

Technologies are developing rapidly; so are our clients' demands. Today it is impossible, if not prohibited, to market a product which is not accompanied by a document in the language of the export country. Be it in the form of a hard copy, disk, or available on-line via the Internet, such documents must be precise, up-to-date, practical and multilingual. If thoroughly conceived, they also allow better usage of the product. This might well have been considered as an additional cost in the past, but such documentation has today become an integral marketing element that accompanies the product throughout its lifecycle, and is therefore also a reflection of its quality.

**What are your objectives when a company entrusts you with its communications?**

It would be strange to start from zero. In principle, we propose functional solutions based on the re-use and optimal recycling of information already available. Managing differences, as symbolised by the  $\Delta$  (delta) symbol in our logotype, constitutes Star's basic philosophy in which only the difference is new. This approach helps us radically reduce costs, manage deadlines - which are often extremely short - and thus guarantee the time-to-market. By way of this, we ensure that the quality of translation is consistent and homogeneous; likewise the content is reliable, while the identity of the trademark is taken into account. The Star Group is at the service of enterprises, wishing to improve the quality of their documentation, and offering them individual analysis with no obligations.

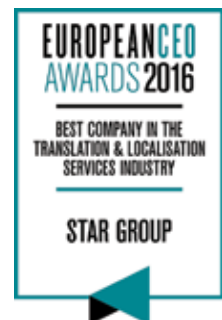
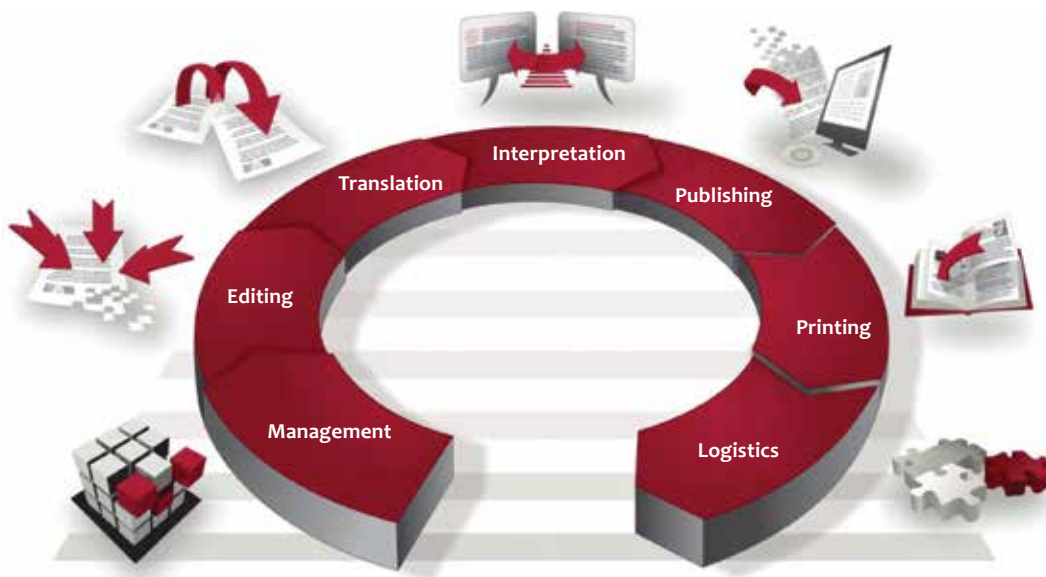

**INVESTMENT**  
Opportunity



## TOURISTIC DEVELOPMENT LAND PLOT

Prime development property located near Bled town and opposite to the Golf Course Bled provides unique investment opportunity in leading alpine tourist destination in Slovenia, visited by 370 thousands tourists yearly.

Project: „Golf Bled“  
Land: 79,659 m<sup>2</sup>  
Development: greenfield  
Type of use: touristic  
Footprint ratio: 30%  
Max. usage ratio: 65%

This greenfield development plot lies right at the regional road connecting Bled with A2 highway. The current planning acts define the property as building land for construction of tourist, sports, recreation and leisure facilities.

The preliminary development designs for the land plot foresee a hospitality complex with restaurant, SPA resort and parking garage in the basement. The southern half of the plot at the edge of the river bank protected forest could be developed for wellness, recreational and park usage. The urbanistic goal is to fuse tourist facilities with the nature and seamlessly passing the development into the protected nature of the Sava river.

The Detailed Spatial Plan is subject to change as long as programme of the investor is aligned with the strategy of the local authority.

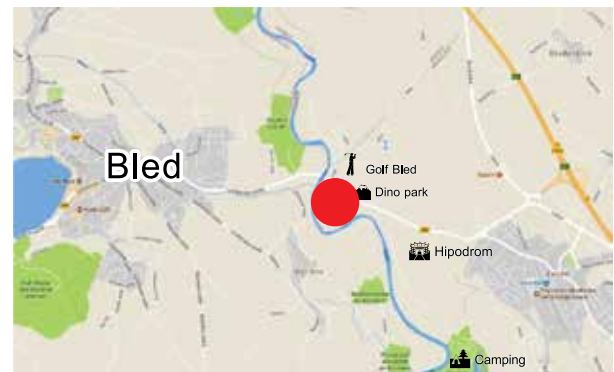

The property lies between the road Lesce - Bled and the river Sava, right across the street of the Golf Course Bled, theme park Dinopark Bled and next to hippodrome Lesce. The real estate is located 2 km from the centre of Bled town and the A2 highway connection Lesce.



HETA Asset Resolution d.o.o.  
Dunajska cesta 167 · 1000 Ljubljana

**Mario Lukić**

Real Estate Transaction Manager

T: +386 (0)1 580 46 39

mario.lukic@har.si

www.aaplatform.com · www.har.si

# First Steps in Setting Up a Business in Slovenia

**You've decided to enter the Slovene market. What do you need to do to be able to do business as soon as possible?**

Barbara Perko

You recognized Slovenia as an ideal environment for your business, you have checked the competition and carried out comparative research as well as a feasibility study. Now it is time to decide whether you will open a representative office or invest in a manufacturing/service company. Foreign companies most often choose to open a representative office or set up a limited liability company.

## Steps in Registering a Business in Slovenia:

### 1. A non-Slovene national will need:

- ✓ a valid personal document (passport),
- ✓ a Slovene tax number or personal identification number,
- ✓ valid personal documents of founders and representatives - if representatives are foreigners, they must provide Slovene tax numbers.

A non-Slovene legal entity will need:

- ✓ a valid personal document of the director general of the legal entity,
- ✓ a Slovene tax number for legal entity,
- ✓ an extract from the company register for the foreign company (abbreviated version), with a certified translation in Slovene,
- ✓ valid personal documents of founders and representatives - if representatives are foreigners, they must provide Slovene tax numbers.

According to Doing Business 2017 it takes seven days to register a business in Slovenia. This places Slovenia in 49th place among 190 countries.

### 2. Foreign nationals will need a temporary residence permit if they intend to manage the business they set up or act as company representative.

The application will need to include:

- ✓ a decision appointing the company representative in the Court Register of Slovenia,
- ✓ a decision designating the name and registered seat or address of the legal entity where the job of the company representative will take place,
- ✓ duration of employment,

- ✓ name, surname, date of birth and nationality of the applicant.

Third-state nationals should file an application for a residence permit at the diplomatic mission of the consular post in their native country.

### 3. The following enclosures must be attached to the request for registration of a limited liability company (d.o.o.) in the Court Register:

- ✓ articles of association/memorandum of association,
- ✓ a transaction account,
- ✓ paid up initial capital of 7,500 euros. A Bank's certificate of initial capital payment must be enclosed with the application for registration,
- ✓ certificate of no criminal record for the founders,
- ✓ certified translation of non-Slovene documents.

**The procedure and the documents required for registering a business in Slovenia depend on the type of business you want to establish.**

**Non-EU, EEA or Swiss nationals will need a work permit to work at the company they set up in Slovenia.**



Photo: Depositphotos



## OUR KNOWLEDGE FOR **YOUR HEALTH.**

Top quality products are our commitment  
and people's health is our motivation.



Krka is one of the world's  
leading generic pharmaceutical  
companies.



Our medicines are used to treat  
more than 45 million patients  
every day in over 70 markets.

We have over 11,000 employees.



[www.krka.biz](http://www.krka.biz)

*Living a healthy life.*

For carrying out certain services foreign persons are advised to obtain a digital certificate, available at SIGEN-CA, Pošta Slovenije, Nova Ljubljanska banka and Halcom Informatika. A foreign physical person can register a simple one-person or multi-person limited liability company in the Republic of Slovenia at VEM offices (VEM Points). Services at the VEM offices are free of charge. Registration of other different types of companies (more complex types of companies) can be carried out at Notary offices. VEM Points are located at CCIS, SPIRIT – VEM, AJPES, administrative units, Chamber of Craft and Small Business of Slovenia, Slovene-German Chamber of Industry and Commerce and Chamber of Business Promotion. The entire process, from obtaining the tax number to registration of the business at VEM Point, takes 4 to 9 days.

### **CCIS can help you**

The Chamber of Commerce and Industry of Slovenia (CCIS) is one of the VEM Points. We can help you arrange everything you need to open up a business in Slovenia. Visit our webpage [www.gzs.si](http://www.gzs.si), call Tanja Jamnik at 00386 1 58 98 105 or send an e-mail to [tanja.jamnik@gzs.si](mailto:tanja.jamnik@gzs.si).





# We make encoders for robots

No matter how excellent the design, a robot still relies on the components used. Position encoders are one of the key components for robot's position, orientation and motion control.

RLS™ non-contact magnetic encoders offer outstanding performance, system safety and stability for robotic applications, such as motor feedback, joint position control, linear motion sensing, gripper and force feedback. The encoders come in a wide variety of shapes and sizes allowing a more flexible system design. Thanks to non-contact magnetic encoder technology RLS sensors bring reliable operation for years to come.

- Excellent price-performance
- Wide installation tolerances
- Industry standard absolute or incremental output options

Explore the wide open range of options and configurations:  
[www.rls.si/magnetic-encoders-for-industrial-robotics](http://www.rls.si/magnetic-encoders-for-industrial-robotics)



**RM08**—Compact, super small, high speed rotary magnetic encoder designed for use in space limited robotic applications



**MBA**—A PCB-level magnetic encoder designed for high volume OEM application



**RoLin**—miniature PCB level incremental encoder sensor system designed for embedded motion control applications

**RLS Merilna tehnika d. o. o.** | 1218 Komenda | Slovenia  
T +386 1 5272 100 | F +386 1 5272 129 | E [sales@rls.si](mailto:sales@rls.si)

Available through our  
webshop:

[www.rls.si](http://www.rls.si)

# The Chamber's Recipe: Contact + IRD Input = contRact

**People with knowledge and experience who give you the best information and assistance at the Chamber of Commerce and Industry of Slovenia.**

*Barbara Perko, Photo: Žare Modlic*

## **Business consulting: highly personalized service**

Contact: Nataša Turk  
email: [natasa.turk@gzs.si](mailto:natasa.turk@gzs.si)  
phone: 00386 1 5898 152

The Centre for International Business (CEMP) provides useful and highly personalized consulting services. It adapts its services to each individual member who turns to CEMP with a request or problem related to the challenge of exporting to or entering international markets.

CEMP has a network of formal and informal contacts in all major international markets, which means that it can successfully address the majority of problems and issues. It provides added value and at the same time relieves companies in terms of time, staff, and financial resources. In 2016, CEMP provided 1,151 one-on-one consultations.

## **Business events: 5,918 event participants**

Contact: Marko Jare  
email: [marko.jare@gzs.si](mailto:marko.jare@gzs.si)  
phone: 00386 1 58985 158

In 2016, CEMP organized 18 outgoing delegations and 12 incoming delegations. It visited nine international trade fairs, which provide an excellent platform for establishing business contacts and monitoring the latest products and technologies in various industries. Delegations are mainly aimed at obtaining detailed information on foreign markets, preparations for market entry, establishing direct contacts, maintaining existing contacts, and transacting deals.

Last year's events were attended by 5,918 participants. In addition to incoming and outgoing delegations and trade fairs, CEMP also organized business breakfasts and contacts at the Chamber of Commerce and Industry. On average, CEMP organizes a hundred business events annually.

## **Networking: 15 inquiries from foreign markets each week**

Contact: Ante Milevoj  
email: [ante.milevoj@gzs.si](mailto:ante.milevoj@gzs.si)  
phone: 00386 1 5898 162

A real business contact that can be immediately used is of immeasurable value. CEMP's know-how and core business is just that, to catch the right context and connect different stakeholders of different backgrounds in new stories, challenges and win-win partnerships. One of CEMP's top priorities is to inform its members of at least 15 inquiries from foreign markets it receives each week. During this process, they both take into account the interest of members and constantly adapting market conditions. Weekly networking events at the CCIS play an important role in facilitating potential partnerships. If you are searching for something »Made in Slovenia«, CEMP will find you the best options available. A number of satisfied member companies and foreign businessmen are proof that this CEMP's know-how is providing a useful platform for new businesses on the global market.



**The Excellent SME Certification acquired by 850 companies and entrepreneurs**



Contact:  
Mojca Osojnik

email: [mojca.osojnik@gzs.si](mailto:mojca.osojnik@gzs.si)  
phone: 00386 1 5898 101

The Chamber of Commerce and Industry of Slovenia has issued the Excellent SME Slovenia Certificate to 850 companies and entrepreneurs, which together account for a 12% share of generated profits in Slovenia, a 6.6% share of revenue, a 7% share of value added, and 6% of all Slovene employees.

Recipients of the certificate report on average 9% higher revenues per employee than other companies of the same size. They generate a higher profit and one-sixth more value added per employee.

The certificate represents credible recognition for strong performance, gives companies greater visibility in the business environment, and also promotes ethical business practices.

**SloExport: Information on more than 6,000 companies in one place**



Contact:  
Andrej Brvar

email: [andrej.brvar@gzs.si](mailto:andrej.brvar@gzs.si)  
phone: 00386 1 5898 461

Sloexport is the database of Slovene exporters, created by the Chamber of Commerce and Industry of Slovenia in cooperation with SPIRIT Slovenia – the Public Agency for Entrepreneurship, Internationalization, Foreign Investments, and Technology. The database contains information about more than 6,000 Slovene companies. Its purpose is to promote entrepreneurship, internationalization, and foreign investment as well as to facilitate the development and transfer of technology.

Users will find necessary contact data and information about the region in which the company operates. Also included is information on the proportion of exports as revenues, the countries to which the company exports, and those in which it would like to export. The data also includes a presentation of the company and their products.



**Discover Slovenia**

The Chamber of Commerce of Slovenia published special editions of the Discover Slovenia - Feel the Brand magazine for individual markets, namely for the Austrian, German and Russian market, as well as the markets of the Middle East and Southeastern Europe. A special edition for the French market will be published later this year. Slovenia can offer plenty state-of-the-art products and services which we will continue to present in our future special editions.

For more information, please, call Nataša Radić (00386 1 5898 399) or send her an email ([natasa.radic@gzs.si](mailto:natasa.radic@gzs.si)).

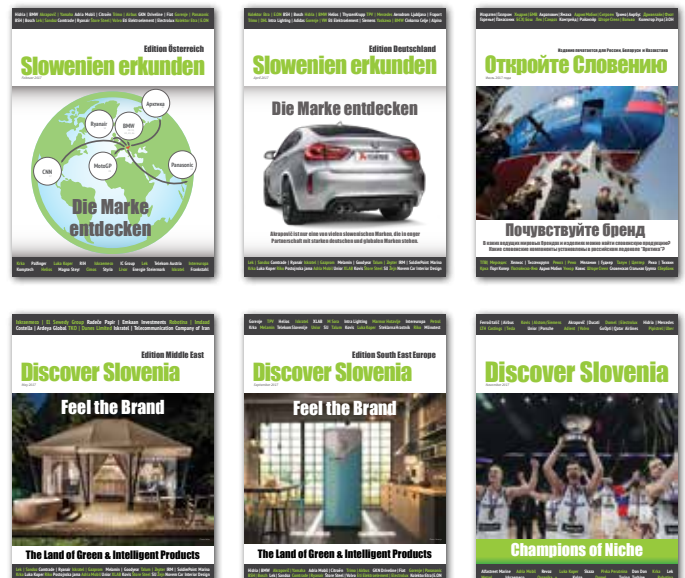

# SITOR

## Stiskalnice d.o.o.

SiTOR stiskalnice d.o.o. is the leading manufacturer of hydraulic presses for use in the production of plastic sheets (PP, PE and UHMWPE). The presses account for 80% of the company's entire output, the remainder being made up of semi-products and of hydraulic presses for the rubber and wood industries. Semi-products include tools for presses used in the production of plastic sheets and heating panels.

Next year the company will celebrate its 40th birthday. In that time it has made its presence felt on markets and in sectors around the world, and its production programme has been adapted to those markets and sectors. Hydraulic presses have remained its main production programme for each of those four decades. The company began making presses for the production of plastic sheets in the mid-1990s, and they have manufactured over 70 to date. The users of the presses are some of the leading plastic sheets manufacturers in Europe and the US, which is proof of their reliability and their ability to satisfy the toughest requirements. The presses are manufactured in line with the customers' requirements. Improvements and modifications are being introduced constantly; these are the fruit of the company's many years of experience and collaboration with customers. The company also has a laboratory press that enables sheets to be produced from various different materials using different technological procedures, and potential customers to test new samples.

The company fully intends to retain its position as the leading manufacturer of hydraulic presses for the production of plastic sheets, and upgrade its activities through greater presence in the rubber and wood industries, where it already has a significant amount of experience. The company regularly attends trade fairs in its fields of operations, where it is more than happy to detail its products to potential customers.



Two-daylight press for the production of plastic sheets.



#### LOCATION

Snežniška cesta 19, 6257 Pivka  
Slovenia



#### REQUEST

[info@sitor.si](mailto:info@sitor.si)



#### CALL US

+ 386 (0)5 72 10 650



#### VISIT

[sitor.si/en](http://sitor.si/en)

Emergency Care Centre at Jesenice General Hospital



Revoz - Modernisation of heating system

Hotel Intercontinental -  
Mechanical Installation



Tunnel Markovec - Electrical installation



Reconstruction of M1 gas pipeline at canal  
crossing at Zlatoličje hydroelectric plant



Trojane - Vodice gas pipeline



Photo: Profimedia

## Slovene Basketball Team's Winning Spirit – Modesty & Passion

**Slovenia is the second smallest country in terms of population to have won the European basketball champion title. Coach Igor Kokoškov effectively blended the unique qualities of each player with their fantastic will to win into an amazing powerful force that distinguished the team. This is the Slovene recipe for success.**

*Polona Movrin*

At EuroBasket 2017 the Slovene basketball team wrote the most beautiful Slovene sports fairy tale. Not only did they win the gold medal, they were the only team that remained unbeaten in the tournament. They defeated Spain, the reigning European champion, 92 to 72.

During the final championship match against Serbia, the team lost two key players at crucial moments of the game. Luka Dončić sustained an injury, while Goran Dragić was physically so exhausted that he could not continue to play. Yet the team did not give up and went on to beat Serbia 93 to 85 and win the EuroBasket title.

In addition to the team gold medal, Slovene players won three additional awards. Goran Dragić,

an NBA player, won the Most Valuable Player award. Together with the 18-year-old Luka Dončić, a Real Madrid player, Dragić was selected to the FIBA EuroBasket All-Tournament team.

Overnight, Slovene basketball players became an inspiration to the whole country as well as a metaphor for those Slovene companies which have, embodying the same spirit, become European and global branch leaders. Many of them are introduced in this 2017 edition of Discover Slovenia – Champions of Niche. But before we introduce these Slovene companies, here are the exclusive interviews with the new European basketball champions and the story of how Slovene basketball players won the European title.

## Coach Igor Kokoškov

### »Leader Goran Dragić is a superstar, yet he doesn't behave like a celebrity.«

Kokoškov, assistant coach for the Utah Jazz of the NBA, was a Serbian basketball prodigy until his budding career ended in a car accident. Aged 24 he became the youngest coach in the history of Yugoslav basketball, and quite soon a very successful one. In 1999 he became member of the coaching staff at Missouri State University, which made him the very first European to hold such a position in the United States university basketball league, the NCAA. Kokoškov was appointed the Slovene national basketball team coach on 18 January 2016.

*You selected teams of five players on the court like a true master. TV commentators often remarked that your choices were extraordinary, but that we should trust you because you always know how to create a winning combination. How did you manage to combine each player's individual qualities into such a strong team spirit?*

When preparing for a particular game we always looked through various scenarios, such as possible situations that might happen during the game and what the players could do in each one of them, etc. Of course, you can never foresee everything, and this is the beauty of basketball; as a matter of fact this is the true beauty of all sports. Every game has its own rhythm, unpredicted situations happen you have no scenarios for and you have to react quickly. It is like a game of chess. We certainly had not anticipated we'd be playing the last minutes of the tournament's final without Dončić and Dragić.

My decisions in selecting five-man teams had nothing to do with my personal attitude to them as people, and the players knew it as I explained it to them. My player combinations were always in the best interest of the team and the game we

**»You cannot be successful in anything you do if you don't have passion in you. When there is a decision to take, however, your mind needs to be clear or you make mistakes.«** Igor Kokoškov

were playing. Our personal relations were utterly unimportant in this. This worked out best for me and best for the boys.

*Your decision towards the end of the finals against Serbia to pull out Dragić due to exhaustion and give the chance to the players who other coaches might not trust enough to let them play the last minutes was a bold one. Weren't you afraid that you might be accused of taking a wrong decision?*

Every decision we make in life entails risk, be it choosing your friends, your future spouse, everything. You can never be sure that the decision you take will turn out 100% right.

If we had lost, it would have been me who would have been criticized the most in any case ... Anyway, at that particular moment I had no time to ponder. I looked at the bench to see which players



Photo: Anže Petkovšek

were available and I sent them onto the court. And the boys did what they had to do. I am really happy that they took the opportunity.

*It was obvious that the whole national team functioned together like one person. You all keep stressing that yours was a collective success. How did you manage to achieve such unity? Did you complete a special team building?*

Our best players are also fantastic people, so my work was easy. Goran Dragić is a basketball superstar, but he does not act like a celebrity and this has an effect on other players. When they see their best

**»I have a family in Slovenia. They are Slovene national basketball team.«** Igor Kokoškov

player acting like a normal person, they follow his example and act like normal people. I had a really easy job.

*How did you manage to stay calm in the most nerve-wrecking moments? You appeared totally calm and composed all the time.*

Feelings are always involved, have no doubt about it. You cannot be successful in anything you do if you don't have passion in you. When there is a decision to take, however, your mind needs to be clear or you make mistakes. We have all invested a lot of feelings in our work. There is a time and place to show your feelings, and the game is not such a time ...

*What are the individual qualities of Dragić, Dončić, Randolph; what makes them better than their opponents?*

All three of them have quite distinct playing styles. What they have in common though is their quality as players and as people. Randolph felt obliged to prove that the Basketball Federation of Slovenia was justified in awarding him Slovene citizenship. Dončić is young and has an honest heart and great desire to improve as a player. Goran, as I have already said, made my job easier by behaving like one of us, not like a celebrity. The boys followed his example.

**At the press conference after winning the gold medal you said: »All the glory should go to the players; I was merely taking decisions.« How can you stay so grounded when so many declare you god?**

The triumph belongs to the players, that's a fact. Coaches do the shouting let's go, let's do it, but it is the players who do the running and create chemistry. The success originates in players. I don't have any illusions in thinking this is my team. A coach cannot be an alpha man, the main player is the alpha man.

**Slovene national team,  
2017 European Champions**

Anthony Randolph (0)	Jaka Blažič (11)
Matic Rebec (1)	Gašper Vidmar (14)
Goran Dragić (3) - team captain	Saša Zagorac (17)
Aleksej Nikolić (6)	Žiga Dimec (22)
Klemen Prepelič (7)	Vlatko Čančar (31)
Edo Murić (8)	Luka Dončić (77)
	Coach: Igor Kokoškov



Photo: Anža Pečkovišek

**Goran Dragić, MVP  
»I believed in the boys,  
I believed in them all  
the time.«**

The EuroBasket final game was the last game the team captain Goran Dragić – Gogi – played for the Slovene national basketball team. Still, he says, this was not the last time he wore the team jersey. He promises to put it on every time he watches the national team play.

An NBA player since 2008, Dragić currently plays for the Miami Heat. His 2015 90 million US Dollars contract binds him to the Heat until 2020. This sum is the highest any Slovene team sports player has ever been paid.

Despite the wealth of his achievements he claims he is just simple Gogi from Koseze, a part of Ljubljana, where he grew up and where he started playing street basketball.

*How did you and Kokoškov manage to combine so well the qualities of individual players that allow you to achieve your maximum as a team?*

The credit goes to Igor. He found the best way for each one of us to show and give our best. We trusted him, we trusted each other and together we strove for the same goal.

**»Igor succeeded in bringing us close as players on the court and as people off the court, I don't think that any other coach has ever done it so successfully.« Goran Dragić**

*When you helped Luka Dončić walk onto the podium to take his all-tournament players award and later when the entire team carried him on stage to collect the gold trophy – you showed the spirit of your team: in good or bad always together.*

*How did you achieve this unity, this rarely to be seen connectedness?*

Let me repeat what I've already said – it was all Igor's doing. He succeeded in bringing us close as players on the court and as people off the court, I don't think that any other coach has ever done it so successfully.

*How was it for you, especially as the team captain, in the crucial moments of the game when you had to stay on the bench and were not able to help the team?*

I believed in the boys, I believed in them all the time. If I hadn't I would have given up and took home the silver medal. But when you play the final you play to win. And that's precisely what we did, we played to win. Of course I was nervous, but I believed in the boys and they showed us all what they are capable of.

**»Igor found the best way for each one of us to show and give our best.«**

Goran Dragić

*You led the national team towards victory over Serbia, yet their media praise you loudly not only for the way you played but also for how you consoled the young Serbian player Vladimir Lučić. Everybody seems to agree that you are a great player and a great person. How did you stay the way you are despite being famous, despite the fans, money?*

I always say I am still Gogi from Koseze. I don't think I have changed much.





Photo: Anže Petkovšek

## **Klemen Prepelič, the man of decision at the end of the final match: »We were all on the court, it was not just me there.«**

Klemen Prepelič proved himself as a player: an excellent three-point shooter, he hit some truly unbelievable shots.

Just one week before the championship Prepelič signed a contract with the French first league team Levallois Metropolitans.

**»Winning makes you stronger and more positive – so with each new game we played and won we felt more connected, even more like one.«** Klemen Prepelič

*After Dončić sustained an injury and Kokoškov took Dragič off the court due to exhaustion, it was you who took the responsibility to lead the team. How did you feel at that moment when you realized that the responsibility fell now on you?*

People keep on saying that I took the responsibility to lead the team, but they all forget the part played by Nikolič, Randolph, Blažič and Gapi. We were all there on the court, it wasn't just me, I was not alone there.

*You too insist that the trophy was a collective success. How did you achieve this incredible team spirit?*

We felt like one from the very beginning. And then – as Igor says, winning makes you stronger and more positive – so with each new game we played and won we felt more connected, even more like one.

*You scored some unbelievable three-point shots. Are three-point shots your strongest ability as a player?*

The ball obviously wanted to go through the basket. No doubt this was our championship. We defeated all the best teams.

## **Edo Murić, the key man on the bench in crucial moments: »Kokoškov allowed us freedom, while Gogi led us like a true team captain.«**

Edo Murić believes Dragič will continue playing for the national team. »If not, I will personally drag him to team preparations.«

Murić has recently signed with Anadolu Efes, the most successful club in the history of the Turkish basketball league.

*You often said that the players were like brothers and not co-players. What created this spirit?*

We had the right leader and the right coach. Kokoškov allowed us freedom,

while Gogi led us like a true team captain. We never complained; we did what he wanted us to do. This team had no egos. Gogi sought no special treatment, although he was our main player.

*How was it for you in those last minutes of the game when neither Dončić nor Dragič were able to play?*

After Dončić's injury I first began to panic, but I quickly collected myself. I told Dončić to stay by the court and support the team. Later, when Gogi was down with cramps, I massaged his legs.

I believed in us. I knew we played fair and that justice will win. I knew we shouldn't give up. And we did win in the end. This is the crown proof of our team spirit.

**»We did what Kokoškov wanted us to do. This team had no egos. Gogi sought no special treatment although he was our main player.«**

Edo Murić

*How did coach Kokoškov manage to get to know you all as players in such a short time and then combine your individual qualities with such success?*

Kokoškov kept in touch with us even during the NBA season. We saw he was interested in how we were doing. He was not going to coach us just at the tournament. He kept in touch with us all those months before and wanted to know how we were progressing as players.

*What are your strongest points? What distinguishes you from your rivals?*

My strongest point is that I am a member of this team. I am happy I had the chance to be part of this family. We are a team, not just a group of individuals.



Photo: Anže Petkovšek

# Innovative tailor-made measuring instruments

**Dewesoft, based in Trbovlje, have been in operation for 17 years and are among the world's leading manufacturers of measuring instruments. Their innovative solutions help leading aviation, vehicle, transport, construction and energy companies to develop products even before their initial installation.**

By using its resources and carrying out extensive testing, Dewesoft enables manufacturers, in the development stage, to develop products to an extent that ensures that they are of top quality, safe, reliable and suitable for use. Dewesoft's comprehensive solutions in the field of measuring technology comprise the high-performance DEWESoft software package, which makes it easy to capture and analyse data. Today the company supplies the market with 45 innovative products. The versatility of these products, in conjunction with a superb software package, makes them among the most innovative on the market.

A number of world-leading companies use Dewesoft products, among them Nasa, Boeing, Škoda, GM, Audi, Toyota, Bridgestone, CAT, Valeo, Rolls Royce, Honeywell, Harley Davidson and Lockheed Martin.

## **A fusion of software and data**

Dewesoft are oriented towards the manufacture of measuring instruments that make use of innovative ideas to combine their solutions with the solutions found in all their competitors together. The company's unique software is thereby becoming an ever-more common component of measuring instruments, therefore constituting a complete user interface for the management of measuring instruments.

The company's mission is to produce measuring applications that feature all its best ideas at once. A complete software package, data capture instruments and the incorporation of both components into comprehensive measuring systems and solutions. They have turned towards the development of tailor-made products that require close cooperation with customers. The company's objective is to maintain its innovativeness, its focus and its competitiveness.

## **A worldwide presence**

Dewesoft's products are used all over the world – and directly in more than 40 countries. It has subsidiaries in Austria, Germany, Great Britain, Russia, China, Sweden, France, India, the US and Singapore, and distributors in other countries.



# DEWESoft®

measurement innovation



*Luxury is timeless!*



„A luxury product cannot and should not follow fashion waves!  
It is something that remains just as special  
in the future as it was in the past.“



BOXMARK is not only one of the world's leading leather manufacturers. The company can cover the whole chain from a single source - from research and development to design and leather manufacturing up to finished products like the premium in- and outdoor furniture line „Xtreme Collection“. Besides the high-end furniture sector, BOXMARK also supplies the automotive, air, sea and rail industries.

**BOXMARK**<sup>®</sup>  
Best in Leather Interior

BOXMARK Leather d.o.o.  
Industrijsko naselje 10, SI-2325 Kidricevo  
Phone: +386 2 7991-600, Fax: +386 2 7991-641  
si.office@boxmark.com | www.boxmark.com



Photo: Adria Mobil

# Every Third New Diesel Engine Contains a Part Made in Slovenia

**From planes for the Indian Army to the best break disc in the world. After 2018 every third new diesel engine produced in the world will contain a part made in Slovenia.**

*Barbara Perko*

## **Akrapovič: From Aston Martin to Yamaha Racing Motorcycles**

The eyes of car and motorcycle enthusiasts light up when they hear the name Akrapovič, the internationally acclaimed exhaust systems manufacturer that designs and produces parts for motorcycles and high performance cars. In 2017, Akrapovič released several state-of-the-art products. The company won the prestigious Red Dot Award: Product Design for its exhaust system designed for the Yamaha T-MAX racing line. In addition to this award winning product, Akrapovič manufactures exhaust systems for Honda CRF1000L Africa Twin, BMW S 1000 RR, Kawasaki Ninja ZX-10R,

Yamaha MT-09, Yamaha NT-10, BMW R nineT, BMW R 1200 GS, and many other motorcycles.

Akrapovič also developed exhaust systems for the MotoGP Ducati, KTM, Yamaha, Aprilia and Suzuki factory teams, and has recently developed a new exhaust system for the Yamaha YXZ1000R four-wheeler.

Akrapovič also produces automobile exhaust systems for BMW M2, BMW X5 M and X6 M, Ferrari 488 GTB, McLaren 570S/570S/570GT, Mercedes-AMG C63, Porsche 911 Carrera Cabriolet/S/4/4S/GTS (991.2), and Mercedes-AMG GT.

High performance exhaust systems for car racing programmes are complex and technically exacting. Akrapovič equips Aston Martin Vantage V8 GTE, which competes in the FIA WEC, BMW M4 DTM, BMW M6 GT#, and the MINI John Cooper Works Rally race series.

The company's latest projects include collaboration with motorcycle producers Ducati (Ducati 1299 Superleggera) and BMW Motorrad (BMW HP4 Race). Akrapovič exhaust systems are used in serially manufactured KTM, BMW Motorrad, Honda, Aprilia, Yamaha, Kawasaki, Ducati, and Can-Am motorcycles, Bentley, Audi, Alfa Romeo, Volkswagen R, Renault Sport, Koenigsegg cars, and in BMW Motorsport, Aston Martin Racing, and several other racing cars. These systems are also used in the MotoGP, MXGP, and WorldSBK racing teams.

Currently, Akrapovič is developing exhaust systems for Suzuki GSX-R1000 and Honda CBR1000RR and for Nissan GT-R, Mercedes-AMG G 63, and Porsche 911 Turbo/Turbo S automobiles.

### FerroČrtalič Produces Indispensable Parts for the Aircraft Industry

FerroČrtalič, provider of high-tech surface treatment solutions, has developed the largest and highest functioning robotic shot peening cell in the region. With the ROBOCELL 6000 ECO machine, it is now possible topeen aircraft turbine engine blades as well as the aircraft undercarriage. FerroČrtalič shot peening technology protects the surface against failures such as stress corrosion cracking. Indispensable in aircraft transport, the ROBOCELL 6000 ECO will be used in the maintenance of Airbus 320 and Boeing 737 planes.

The product, which can be adapted to customers' specific needs, is composed of a chamber with a heavy industrial duty 6-axis robotic manipulator and two axis workpiece manipulations with servo driven turntables that allow flexibility of peening with both ferrous and nonferrous types of peening media as well as immediate evaluation and confirmation of peening results. FerroČrtalič develops specific solutions together with the engineering personnel of its customers, and provides start-up training, upgrades, and round-the-clock control.

FerroČrtalič is currently developing several products for the aerospace and automotive industry, including components for ecologically efficient internal combustion engines and electric vehicles.

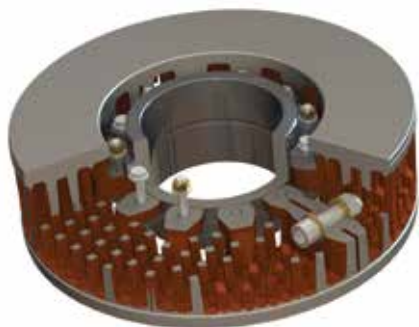

Photo: Kovis



Photo: Akrapovič

As from the beginning, the excellence of the products of Akrapovič, proved on the racing tracks, has spoken to Yamaha; as much on the quality of the research & development as on the manufacture of the exhausts ranges, realized by the brand.

In response to the growing notoriety of Akrapovič, Yamaha has always wanted, year after year, to strengthen the ties between our two companies. In this context, Akrapovič has become the exclusive technical partner of all official teams of Yamaha in all world racing categories: MotoGP, Superbike, Supersport, Dakar, Motocross, Enduro, etc.

Years after years, this fruitful collaboration has given Yamaha the opportunity of conquering many world titles. And behind this collaboration of images, based on a high level technology, Yamaha has designed exhausts ranges exclusively for our own products, ranges that have been developed by Akrapovič. The commercial expansion and the growth of the sales obtained in just a few years, is a perfect »school« example.

With such fundamentals, the strength of the technological partnership and the commercial cooperation between Akrapovič and Yamaha will last for many years, and we will surely find other ways to develop this partnership on new territories.

*Eric de Seynes*  
COO of Yamaha Motor Europe



Photo: Personal Archive

### Kovis Produces the Best Break Disc for Freight Wagons

Last year Kovis, one of the leading European companies for development and production of components for the railway industry, launched a new disc brake for freight wagons. The product has achieved 18% better results than similar products on the market, and is currently the best of its kind in the world.

Kovis also developed its own axle box type Y25/25t that can be used for 25 and 30t axle loads and in which the weight of the casing has been reduced by more than 15%. The new casing is completely interchangeable with the existing BA386 axle box housing.

Kovis has received funding from the EU Horizon 2020 research and innovation programme to develop a revolutionary solution, namely the Divided Rail Freight Brake Disc (DRFB disc) that could potentially influence the following three elements in rail freight transport: 1) safety and security, 2) health and environment, and 3) cost-effectiveness.

Kovis's customers include some of the world largest manufacturers of railways vehicles: Bombardier, Siemens, Alstom, Stadler, Vossloh, Škoda, and others. Kovis develops technical solutions that suit individual customer's specific needs. For example, the company developed a special break disc for the latest Siemens ICE 3 generation of rapid trains to be used by Deutsche Bahn. The company is also developing an M7 gear housing for trains that will be designed by Alstom for the SNCB Belgian railway.

**Hidria in Every Fifth European Car**

Hidria has become an important pre-development partner and supplier in the automotive and industrial segments as a result of its breakthrough innovative solutions, supplying companies such as Audi, BMW, Bosch, Bitzer, Continental, Caterpillar, Ducati, Fiat, Grundfoss, Great Wall, KTM, Nidec, Jaguar, Mercedes, Opel, Porsche, PSA Peugeot Citroen, Renault, and Yanmar.

Hidria's solutions are essential to the high performance electric engines made by Audi, Citroën, Mercedes, Peugeot, Renault, Volkswagen, and other brands. The company provides innovative solutions for mild hybrid vehicles made by Audi, Chrysler, Renault and Volkswagen, and for intermediate hybrids including the Peugeot 3008 and 5008 Hybrid, and for Volvo's entire hybrid platform. It also supplies parts for the hybrid Porsche 918 Spyder and Panamera, the Fiat 500, and the all-electric Mercedes e-SLS.

Hidria's electric motors are also used as component parts in professional hand tools and innovative HVAC solutions in the field of heating, ventilation, and air conditioning. The company develops and produces innovative electron fans with an external rotor, which are characterized by low noise and high-energy efficiency.

Hidria also develops a world-renowned system for the cold start of diesel engines. With the internationally acclaimed pressure sensor system Hidria Optymus PSG, a modern diesel car will consume up to 30% less fuel and will reduce emissions to the

environment by up to 30%. The system will begin to be delivered in 2018. After 2018, every third new diesel vehicle will be equipped with this system in Europe and beyond.

Hidria's existing cold start systems for diesel vehicles are built into the latest models of the Peugeot 3008 and 5008, the Citroën C3, all Fiat vehicles with 1.3 Multijet diesel engines, and the newly designed Renault Clio.

Each fifth new car manufactured in Europe (including, among others, the Citroen C3, Seat Leon, Škoda Fabia, VW Golf and Mercedes C and E series) has a propulsion system and a steering system that includes Hidria parts. The company also produces aluminum engine chains for 8 cylinder engines for the Audi A6 and A8, and Porsche.

Hidria is one of the leading developers and manufacturers of aluminum and steel frames and other technologically and technically demanding welded parts for motorcycles. Hidria frames provide the core of BMW's latest models, the R Nine T, the F 800 GS, the C 650 GT, the S 1000 XR as well as the Ducati Diablo, the XDiavel, and KTM's two-wheelers.

After 2018, every third new diesel vehicle in Europe and beyond will be equipped with Optymus PSG system for the cold start of diesel engines.

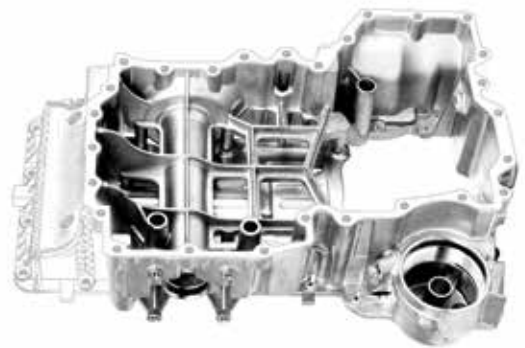

Photo: LTH Casting

**LTH Casting Products in Tesla Automobiles**

LTH Castings works in the field of complex, mechanically processed aluminum castings made to customer specifications. The parts are installed in drive assemblies, and braking and control systems. In the future, the company intends to extend the portfolio of its castings to bodywork parts.

LTH's parts are present in almost all European vehicle brands. The company directly supplies virtually all lines of engines and transmissions for Mercedes and BMW automobiles. In most cases, LTH is the sole supplier. The company is also present outside of Europe, their parts being used in Tesla automobiles. LTH also sells steering mechanisms, electronic components, and brake parts to systems suppliers such as Bosch, Continental, and Wabco. LTH was the first foundry to receive the Daimler Prize for global supplier of the year (in 2013).

Currently, the company is preparing a series for new Mercedes engines, front differentials for four-wheel drive engines for Mercedes and BMW, electric refrigerators for electric engines, and very complex



Photo: Hidria

components for automating the gearboxes of trucks. Special emphasis is placed on the development of technologies that are not yet established and which have the potential for breakthroughs.

#### **Unior: The First Project for Porsche Electric Car**

In the past year, Unior has started a pilot forge programme for the first Porsche electric automobile. It has supplied the first samples for an electric vehicle from the VW Group and axles for passenger cars for its customer JLR.

With the products in the forge programme, Unior has become one of the most important suppliers of forged automotive parts to the largest automotive manufacturers: Volkswagen, Audi, Škoda, Porsche, Bentley, BMW, Ferrari, Renault, Dacia, Hyundai, Kia, Jaguar, Land Rover, and Volvo. The company's parts are present in hybrids, and it aims to supply the new generation of fully electric vehicles. The company also has plans to focus on forged aluminium products.

This year, Unior's Special Machines programme is presenting the TANDEM 700 L Universal Double-Spindle Center. This latest product of the Special Machines programme is intended for large-series production of high precision and mirror workpieces, replacing three machines previously needed for this process. The company is also developing a 5-axis double-spindle machining center for smaller workpieces and a special solution for the machine that produces automobile chassis.

Unior's main customers for its hardware programme are Volkswagen, Audi, BMW, Renault, Dacia, Peugeot, ZF, Lemförder & ZF Lenksysteme, Volvo, Bosch Siemens Group, Daimler, Jtekt, GKN, ArvinMeritor, and General Motors. Unior supplies these companies with crankshaft grinding machines, machine units for manufacturing large structural car parts, machine units for manufacturing engine parts, gear cutting machines and deep drilling machines.

In terms of Unior's hand tools programme, it especially highlights its modular workshop equipment and innovations in the field of hand tools for bicycle repairs. The company also announced a project for the upgrading of its plier series, including the renovation of handles and the optimization of design and technical elements. The company is developing a line of tools for work at heights, which is anticipated to include 340 tools and a trolley equipped with an RFID (Radio Frequency Identification) system.

Unior's programme of hand tools has been introduced on Amazon's German site. The company's catalogue of 5,500 products is now available to the 82 million strong market.

#### **Pipistrel Developing Aircraft for Uber**

Pipistrel plays a central role in the Mahepa and Uber Elevate projects to develop a hybrid engine that will improve efficiency and reduce other negative effects of aircraft on the environment. The company concluded a long-term agreement with Uber to collaborate in the manufacturing of electric vertical takeoff and landing aircraft (VTOL). The company also intends to work with Uber on the development of planes for short-distance flights within urban areas using VTOL capability specifications.

Pipistrel's most unique innovation last year was the Alpha Electro, the first two-seater electric plane designed to teach beginners how to fly. The electric drive has zero emissions and reduces the cost of training a new pilot by 70% due to lower operation costs. The plane is completely silent and therefore causes no disturbance to the surrounding environment. The pilot and student do not need a headset and microphone to communicate with each other.

Pipistrel's planes are used by NASA, Siemens, and many well-known individuals. They are also used by three branches of the Indian Armed Forces to train their pilots (the air force, the navy, and the National Cadet Corps).



Photo: Unior

LTH's parts are being used in Tesla automobiles.



Photo: Pipistrel

Our cooperation with Pipistrel started in the year 2000 and we have seen outstanding and exceptional growth in both of our companies during the past 18 years. Pipistrel USA and Pipistrel Australia have become one of the leading aircraft representatives in our markets. This has been achievable because of the exceptional products and quality being delivered by Pipistrel. All Pipistrel products have the very best performance available, they are quiet and environmentally acceptable with the lowest fuel consumption in the industry. There is much interest in the electric aircraft range in which they are the leading in the world. The outstanding quality of Pipistrel aircraft far exceeds any other producers in Europe or in fact anywhere else in the world. Finally, we have developed absolute confidence in the Pipistrel company and in particular Ivo Boscarol over the past 18 years because they have stood behind every product they sell offering outstanding support and after sales service. Representing Pipistrel in almost 50% of the world's markets would not be possible without such a good product and such a strong support network.

*Michael Coates,  
Pipistrel USA and Pipistrel Australia*



Photo: Adria Mobil

#### **Adria Mobil: New Series of Prestigious Caravans**

Adria Mobil will introduce a number of innovations during the 2018 product season. Adria will launch the completely refurbished Action holiday caravan, preserving its original shape, but adding a new generation of convenient and functional features. Adria will introduce a newly designed mobile home for Coral, Adria's best-selling series. Functionality is upgraded with the extremely useful double bottom, double roofing window, and high stand height, which gives an extraordinary feeling of space within the interior of the mobile home.

For the new season, Adria has also developed the Supreme edition, a prestigious series of mobile homes. The series represents the top of the line in modern leisure vehicles. Premium Edition mobile homes feature silver bodywork and aluminum design, Adria's top-level Complex body design, and Alda warm-water floor heating.

The Matrix range of motor homes remains one of the most versatile brands. Adria's brand of refurbished vans has also been upgraded and now includes Citroën and Fiat chassis. The Sun Living brand, Adria's broadest and most competitive entry-level category of leisure vehicles, has been completely updated.

#### **Glamping Mobile Tents Sold in Japan**

Adria Home, Europe's leading producer of recreational vehicles, proudly presents the new MLine of mobile homes, glamping mobile tents and One Stop Shop services. The all-new MLine represents the new generation of mobile homes of the upper middle price class. From the entry-level to fully-customized units the new MLine offers better space optimization, modified layouts and new features and equipment at a competitive and affordable price.

Innovatively-styled glamping mobile tents with contemporary interiors and unique Adria solutions appeal to new target audiences and have opened up new markets. Adria leads with new forms of patented mobile tent construction, designed for efficient transport and assembly. This product has reached new markets such as Spain, Sweden and Japan. In 2018, we can expect the new Safari Loft model, a mobile tent based on a classic safari design with a spacious upper floor and a balcony.

Adria is the most professional One Stop Shop for camping resort operators. No one else can offer such a full service, from standardized and custom mobile home and mobile tent manufacturing right through to full support in architectural consulting, financial services, delivery and installation. Accommodation in such resorts can be booked through Adria Holidays. Glamping Olimia Adria Village, part of the award winning wellness & spa centre Terme Olimia, was announced as one of THE BEST GLAMPING 2017 in Slovenia.

The tourism industry is thriving and the demand for Adria Home products is growing. The company has entered markets in Scandinavia, Spain, Portugal, Germany, Austria and Greece. In 2018, Adria Home will launch a modular mobile housing unit Alpline for all season residence. Highly insulated with robust construction, it is ideal for ski resorts up to an altitude of 2,000 metres. This prefabricated, fully equipped and high performance building delivers remarkable experiences for customers and opportunities for resorts.

#### **Alfastreet Marine: New Standards in the Nautical Segment**

Alfastreet Marine is engaged in the boutique production of boats with distinctive design. The Alfastreet Energy 18 and Energy 23 boats represent new trends in the nautical segment and set new standards. The second of these two boats meet the highest standards of safety, and have B category CE Certification.



Photo: Adria Dorn

Adria Mobil's Supreme edition represents the top of the line in modern leisure vehicles.



The most attractive and important feature of this boat is a hard hydraulic lifting roof made of carbon fibers with sliding doors on the side. Remote control can be used to close the doors from 30 metres within 30 seconds (similar to the mechanism on a cabriolet car), completely protecting the boat from external influences.

Today Alfastreet Marine boats are sold in Slovenia, Italy, Austria, Hungary, Switzerland, Germany, Spain, Denmark, and England. In the future, the company aims to enter the remaining European markets, as well as the American and Asian markets.

### Adient Convinced Volvo with Its High Quality Headrests

Adient Slovenj Gradec is a successful supplier of many products for the interior of automobiles. In the past year, they have begun to supply the Volvo Car Group with their high-quality products, including headrests, armrests, and interior trim for the space between the rear seat and the mudguard.

Adient's products are intended for mid- and upper-end automobiles. The company supplies customers in the automotive industry with headrests, arm and elbow rests, cushioned foam trim, and a variety of small and larger products such as seats and pillows made from molded polyurethane (PU) foam.

Currently, the company is focusing on automating its manufacturing processes. On the technological side, it is focusing on reducing excess weight of its products.



Photo: Adient

### TPV Offers Its Own Automated Guided Vehicle

TPV is currently developing a range of high-tech products for the chassis and bodywork of premium car manufacturers (BMW, Volvo, Daimler, etc.). The company is also developing comprehensive solutions in the field of Industry 4.0 automotive manufacturing, making it possible for its clients to increase the automation of production processes and streamline internal logistics.



Photo: Alfastreet Marine

Within this segment, TPV conceived the innovative Optimatik 160 - a versatile automated guided platform. The key advantage of the Optimatik 160 is the central control system and the size of the vehicle itself. It is lower than the wheels of standard automated guided vehicles (AGV) and thus considerably reduces manipulation costs as it is able to operate without rework. Indeed, with a width of 420mm it is also eminently suitable for transporting standard EURO pallets without rework. This significantly reduces the cost of introducing the system.

### GKN Driveline Slovenia Developing Custom Designed Driveline for New Customer

GKN Driveline Slovenia, the leading automotive driveline technology and systems engineer, is currently developing a custom designed driveline for a new customer, which will begin manufacturing cars in



Photo: TPV



GKN Driveline has designed and put on the market new drivelines for Jaguar Land Rovers and Ford cars.

Photo: GKN

Central Europe. In addition to GKN's drivelines, the company is also known for its homokinetic joints and tripods in a range of types and sizes that are used in automobiles made by the most renowned manufacturers.

In the past year, GKN has designed and put on the market new drivelines for Jaguar Land Rovers and Ford cars, as well as new components for drivelines

aimed at other well-known European car manufacturers such as Mercedes and Volvo.

**Revoz Begins to Manufacture Electric Vehicles**

In the past year, the car manufacturer Revoz added two more types of vehicles to its product range. Smart Forfour EV and Clio IV were added to Twingo and Smart Forfour, which have been produced by Revoz since 2014. Revoz is already negotiating another type of Renault car that will be manufactured in Slovenia.



Photo: Renault



**OMCO** OMCO FENIKS SLOVENIJA d.o.o.



**Production ranges:**

- Castings for the glass making industry (tools for glass bottle production)
- Pump, hydraulic, electrical and mechanical engineering industry product line
- Bells and other individual castings product line

**Material qualities:**

- Gray irons
- Low and high alloyed steel
- Aluminum bronze
- Ductile irons
- Compacted graphite irons
- Niresist and Nihard irons
- Materials according to customer requirements

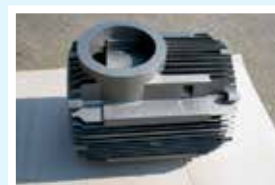

**Production process:**

- Certificate of ISO management system 9001 and 14001
- Maintaining standards for quality and environment
- Environment licence IPPC (Integrated Pollution Prevention and Control)



*good ideas create future*

**Leader in design & production of brake discs, bearing housing, axle boxes and various parts for the railway industry and other industry sectors.**

In joint development to improve the quality and safety of life of over 55 million EU citizens who live or work near train tracks, we developed **revolutionary brake disc DRFB** that follows:

- ⊙ Safety and Protection
- ⊙ Health and Environment
- ⊙ Cost-Effectiveness

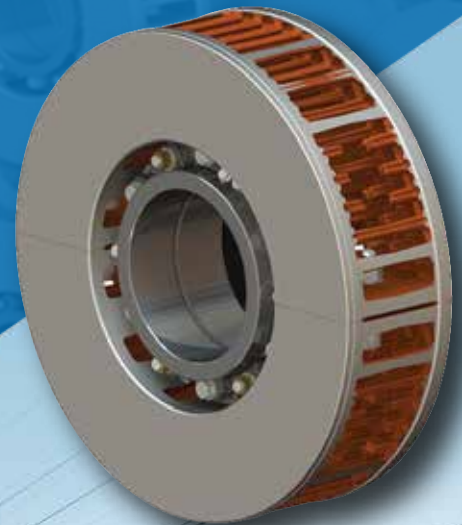

New revolutionary brake disc DRFB  
(EU Project Futura)



The FUTURA project has received funding from the European Union's Horizon 2020 research and innovation programme under grant agreement No.700985

+386 7 499 11 80  
info@kovis-group.com  
www.kovis-group.com



Photo: Kolpa

# From Fully Automated Home to Crystal Door Handles

**With this Slovene-produced system, you will be able to monitor your house when you are far away from home.**

*Barbara Perko*

## **Robotina: Smartly Monitoring Your House Through Your Telephone**

Robotina has developed a third generation of the house automation system called HIQ that guarantees greater comfort, security, and economic savings, and increases the value of the home. The system is a simple application that can be quickly and reliably operated both at home and from remote locations. All you need is a smartphone and access to the internet.

The HIQ system is comprised of engineering and programming features. The system is adaptable, adjustable, and programmable, and integrates

various functions in a single independent unit. It can also be used in an industrial environment.

The automation system combines HIQ home and a smartphone (HIQ Commander application). It performs its tasks automatically and sends commands to the HIQ Commander or the smartphone. Optimal user experience is achieved with presence sensors, door sensors, information from the smartphone and other sources. The automation system can run on the most basic foundations, or it can be extremely advanced, even including artificial intelligence functions.

The system perceives the owners' presence or absence in the home, and appropriately responds to unusual events. For example, it detects dangerous gases, flooding, fires, and other unsafe conditions. It detects arrivals and departures of residents and performs desired functions through the operation of timed settings. Users can manage lighting, heating, cooling and ventilation functions, all of which can be set according to specific schedules. The system sets the optimal temperature according to the set schedule and also ensures the most economic use of energy.

### Gorenje Smart Kitchen Assistant Helps with Recipes

This year Gorenje presented a premier new generation of household appliances with the Gorenje and Asko trademark. These products are complemented by Connect Life appliances and the smart kitchen assistant that reads recipes aloud, provides advice about appropriate food storage and related matters.

The smart induction cooking system Gorenje IQ – featuring the widest surface of any Gorenje product, an advantage for the use of various sized cooking pans – is equipped with smart IQ sensors that automatically adjust the operation of the cooking system, and an advanced user interface for easy use.

The new generation of installed Gorenje refrigerators is built on the NoFrost advanced technological platform, which adapts to user habits, establishing a microclimate in the refrigerator that is similar to nature and in which food will remain fresh for the longest possible time.

The new Gorenje WaveActive washing machine and dryer have a unique and innovatively shaped WaveActive drum that guarantees impeccable washing and drying of laundry with minimal wrinkles and maximum energy efficiency. WaveActive appliances will be available on the market in 2018.

Asko, Gorenje's more elite trademark, features a washing machine that has a special programme for sensitive crystal glasses. Asko developed the machine in collaboration with the Swiss glassware company Orrefors.

### TEM Čatež: Turning Lights On and Off Without Touch

Among the novelty products offered by TEM Čatež are TOUCHLESS light switches, allowing users to turn lights on and off without their hands. The company also developed a new generation of LED dimmers for both families of switches and completed the product line with smaller, more efficient USB storage devices. Other innovations include the MODUL MANAGER switch and socket configurator, which allows the simple reading of the electric meter.

TEM Čatež's best known and most popular product is MODUL, a modular system of switches and electric sockets offered in three designs: Line, Soft, and Pure. These products are used in large hotel chains,



Photo: Robotina

vacation rentals, apartment houses, public institutions, mobile home, sail boats, etc. The Pullman Hotel in Paris, the Privo Hotel in Romania, Adria mobile homes, and Elan sailboats, are among TEM Čatež's most elite customers for these products.

### Turna: Household Appliance Components for Miele, Gaggenau, Panasonic, and Sharp

The Turna company produces under the brand name XTurn a line of high quality hinges for soft and quiet opening and closing of oven doors. The company is the first in the world to develop a completely adjustable solution for the soft opening and closing of oven doors in the product segment of appliances that weigh over 20 kilograms. The system has a life cycle of 80,000 openings and closings. Gaggenau, Gorenje, Panasonic, Vestel, Sharp, Asko, Gram, Amica, Haier, Termikel are among the most elite purchasers of the XTurn hinge system.

Turna also produces magnetic and non-magnetic sealers under the brand name TurSeal, which are used in the Liebherr company's line of refrigerators, freezers, and wine display cases. This product is also used in Miele, Gorenje, and Panasonic refrigeration equipment.

**Gorenje is introducing the virtual assistant or Chatbot named Anna, which advises users on the Gorenje website in the selection of Gorenje products.**



Photo: TEM Čatež



Photo: Rogaška

**The Turna company is the first in the world to develop a completely adjustable solution for the soft opening and closing of oven doors in the product segment of appliances that weigh over 20 kilograms.**

Last year, the globally renowned Bombardier transportation company began to purchase Turna's TURVAC vacuum insulation panels, one of the most advanced forms of insulation. TURVAC are the thinnest insulation panels that provide an exceptionally high level of insulation and thus the optimal use of space in various appliances. TURVAC panels are also used in refrigerators and freezers manufactured by Gorenje, Panasonic, and Vestfrost, as well as in high insulation boxes for transporting temperature-sensitive cargo, such as the Topa thermal containers. Turna also produces heaters that are used in appliances manufactured by Gorenje, Panasonic and Mora. Currently the company is developing a system of oven doors that open and close automatically as well as new soft and quiet hinges for side-opening oven doors.

#### **Kolpa Following the Trend of Freestanding Bathtubs**

The Kolpa company has developed a line of freestanding bathtubs in a range of colours, which is the trending product of this year. The company is also producing a series of shower trays from poured marble with relief surfaces, has expanded its line of shower enclosures, and is offering a new collection of bathroom furniture. Kolpa also expanded its range composite material Kerrock sinks and bathtubs. Kerrock, considered the material of the future, is used by global manufacturers including Nike, Sony, and BAT.

The company is also developing a new programme called Kolpa Solutions, a service that will offer integrated solutions on projects and will be brought in during the first phase of construction. Requests for integrated bathroom solutions led to the Kolpa san Premium programme, which emerged in collaboration with a renowned German architect. In the context of this programme, a new collection of bathroom equipment and furnishings is being designed, and a new range of Kerrock colours generated based on this innovative conceptual design approach.

#### **Rogaška Glasses in the Intercontinental Hotel Chain**

Rogaška Glassworks made a sales breakthrough at the Intercontinental Hotel chain. Rogaška crystal glasses and chalices from the Omega series, developed specifically for the Intercontinental chain, will be used and displayed in the most prestigious Intercontinental restaurants and rooms.

In recent years, Rogaška has created several new series, including 4 Elements and Avant-Garde. The company has begun to collaborate with several producers of top-drawer spirits in order to design bottles for the most prestigious cognacs and whiskeys.

The Rogaška company aims at creating »not-every-day« items from crystal glass and it is in this segment that it is trying to expand its activities. One of the most exciting new Rogaška products are prestigious faucets for the Hansgrohe company, for which Rogaška produces the crystal body and mouths of the faucets. Rogaška also developed crystal handles for faucets in collaboration with the Slovene company Pinar. Rogaška produces a series of crystal chandeliers and table lamps for Waterford, the largest seller of crystal products in the world.

#### **Steklarna Hrastnik: a Collection of Perfume Bottles**

Last year, the Steklarna Hrastnik glass factory entered the perfume and cosmetics segment. In collaboration with top designers, among them De Bachmakoff, the renowned French design agency, Hrastnik designed and developed a collection of ten HighGlass super premium quality perfume bottles.

Recently, the collection of bottles under the HighGlass spirit brand name added three new bottles. The tableware programme expanded to include a mini-version of the Puzzle bowl, and added items to the Jack family, which is intended for the HORECA segment. The company is designing a number of innovations in the field of glass tableware, and intends to develop new families of products, including pitchers for beer.



Photo: Kolpa

Hennessy, Heineken, Villeroy&Boch, Sainsbury's, Bacardi Martini, RZB, Northern Lighting, Lightyears, XAL, Robers, and Axo Light are among Hrastrnik's most prestigious customers in the segments of special glass packaging, glass tableware, and lighting.

#### **Kovinoplastika Lož: Alveus Kitchen Sinks Also for Renowned Nobilia Kitchens**

In the past year, Kovinoplastika Lož has introduced as part of its PC Inox programme new models of stainless steel kitchen sinks in a range of coloured tempered glass, as well as kitchen sinks made of high quality composite material. Making use of mono technology, the company has designed and created a volume spacious kitchen sink that enables all installation modes. The company has successfully introduced its Alveus kitchen sinks and mixer taps to the following sales chains: King Fisher, Leroy Merlin, and renowned Nobilia kitchens. The company produces also components that are incorporated into Rational professional kitchen equipment as well as components for Audi and Porsche cars supplied by Magna.

Currently, Kovinoplastika Lož is in the process of developing a new family of stainless steel kitchen sinks and setting up a Custom Shop concept where customers will be able to create their own kitchen wash stations, using the mix&match system to select from various metal shades of kitchen sinks, waste outlets, and mixer taps.

As part of its PC Okovje programme, Kovinoplastika Lož is developing the ARX programme for the production of building fittings for PVC and wooden windows, tilt-swivel window fittings, fittings for sliding walls, and door fittings. The D25 door lock system is among the top products of the last year, and the company is currently developing the Comfort automatic door lock system. The special feature of this product is its integrated system that automatically activates the elements. The door closes at six points, which greatly improves sealing, reduces heat loss, and lowers energy costs. There is also a reduction in noise emissions from the surrounding area, which improves the quality of living.

In addition to building hardware, the company also produces components for the automotive industry, for Elan skis, and for household and other small appliances manufactured by Bosch.

#### **Domel Has Developed a Vacuum Cleaner Motor That Weighs Less Than 500 Grams**

The new energy label requirements for vacuum cleaners in 2017 includes limiting input power to less than 900 W. Domel has taken advantage of these opportunities and developed a new family of vacuum cleaner motors which meet the energy label requirements from A+ to A+++.

Domel has also developed a new family of motors for use in the new stick vacuum cleaners which is notable for having the smallest dimensions and lowest weight in its class, just under 500 grams.



Photo: Kovinoplastika Lož

Domel's new production line of brushless motor drives (EC motors) to be used in washing machines is designed with an aim to become a leading European producer of washing machine motors. Domel's research and development department actively engages in innovations in the area of electric mobility, developing motors for single-track vehicles such as e-bikes and electric scooters, for instance. In the area of automotive industry Domel focuses on auxiliary electric motor drives and development of innovative technologies for the manufacture of electric vehicle components.

Domel's partners are most prestigious global companies. Domel vacuum cleaner motors are used by manufacturers such as Philips, Electrolux, and Rowenta. In the segment of professional cleaning, Domel has set world standards with its vacuum motor for wet aspiration and persuaded segment leaders,



Photo: Steklarna Hrastrnik

such as Kärcher, Nilfisk, and Lavorwash. Domel's compact EC motors are used in professional combi steamers manufactured by Rational AG, the global segment leader.

Domel high energy efficient EC motors are used in products manufactured by Husqvarna and Stihl, two leading brands in the professional segment of cordless garden equipment and power tools. Domel is the exclusive motor supplier for a particular segment of their programme. Domel motors and automotive components are built-in all leading European brands, such as Mercedes, BMW and others.

**Danfoss Trata Is Developing Three Innovative Systems**

Danfoss Trata is the world's leading technology supplier and provider of energy efficient solutions for buildings, infrastructure, agriculture, and the environment. In more than 45 countries around the world, the company offer a wide range of products for use in district heating, and the regulation of heating and air conditioning in residential and commercial buildings.

Danfoss Trata has transformed their MCV regulation valves, combined flow and pressure control valves (ABQM, AVP, AFP, etc.), balancing valves (ASVs), and heat exchangers into products with strong global brands.

In the past year, the company has implemented two major upgrades to their NovoCon S innovative intelligent drive. They have also upgraded the smaller-dimensions automatic ASV balancing valves, and developed a new, universal XB25 heat exchanger using innovative microplate technology.

The company has developed the following three innovative systems within the programme of new Virtus solutions aimed at improving the operations of district heating systems: iNET, a solution for balancing the district heating network; iSET, a new solution for eliminating temperature fluctuations in buildings, and; Dynamic Damping innovation, which adjusts the amount of water that can enter the pressure drive.



Photo: Danfoss Trata

These products are more compact, have a higher bandwidth, and deviate less from set values than previous solutions. They also feature two intelligent functions. The three products will be launched on the market at the beginning of next year.

**Skaza: the Environmentally Friendly Picnic Puzzle**

This year Skaza launched the global innovation Pick&Go picnic set for families, groups of friends, and associations promoting life in nature. It features a unique and innovative picnic jigsaw puzzle, put on the market as part of a new category of leisure products entitled EcoBiB Outdoor. This designation marks environment friendly products made from advanced bio-based smart plastics. Currently, the company is in the process of upgrading the Bokashi Organico domestic compost system and developing a new specialized travel mug.

This year Skaza began to work with one of the world's largest manufacturers of office equipment. For more than 25 years, it has been working with the world's most recognized brand in furniture, home, and leisure products. Its product line includes chairs, a range of baskets, household waste containers, thin walls, and other products from a combination of wood, metal, and plastic.

Skaza is also present in the automotive industry where it specializes in the injection moulding of components including mechanical parts for head and armrests, various containers for interior decoration, front and rear lamp cases, and electronics. In the latter segment, the company is most recognized for their plastic housings for various products.

Skaza launched the global innovation Pick&Go picnic set for families, groups of friends, and associations promoting life in nature.



Photo: Skaza



**Paloma: Novelties for Pets**

Paloma is adding new products to its Care segment. This year the company upgraded its entire Deluxe toilet paper line, improving quality, and adding new products. It is providing customers with a new Pro Pet segment that includes pet towels. In the area of cosmetic tissues, the company manufactures a line of Carbox products specially designed for use on the road. They also expanded their Junior series for children.

Paloma's most important wholesale lines for large customers are Paloma Care and Paloma Professional (the »away from home« programme). This year's New Years-Christmas collection of napkins with holiday motifs is already on the market.



Photo: Paloma

# LUKEM

## LINK IN BUSINESS

We are a chemical trading company that understands your needs. In today's world of quick changes we provide more than just products. We bring in new thinking, creativity and numerous business opportunities.

Lukem has partners across the globe so while analysing global happenings our services incorporate in-depth knowledge of regional markets. The above reflects in a first-class business experience our clients enjoy.

### We are specialized in raw materials for:

- Paint Industry
- Synthetic Resins
- Detergent Industry
- Fibreglass Industry
- Food Industry / others



LUKEM d.o.o. Phone: +386 1 244 32 91-3

Tiranova ulica 38 Fax: +386 1 244 32 96

1000 Ljubljana, Slovenia e-mail: lukem@siol.net



I FEEL  
SLOVENIA

# SLOVENIA

Europe's new must-visit destination

*Slovenia is Europe's best-kept secret. Sharing a border with the north of Italy, this is a land of natural beauty and diversity where the warm Mediterranean breeze rolls in towards the Alps and where mountains, rivers and thermal waters combine to create one of the greenest natural playgrounds on earth.*

## Adventure and discovery

This is a country that embraces adventure and discovery in the natural world, be it hiking the Alpe Adria Trail, cycling through verdant Italian-style olive groves or canoeing the turquoise waters of the iconic Lake Bled. At the crossroad of Europe, such diversity is packed into a country smaller than the state of New Jersey - it is just a two-hour drive from the highest peak of

Mount Triglav to the coastal Venetian architecture of Piran.

Hidden amongst Slovenia's emerald green lakes and snow-capped peaks are towns and cities rich in cultural heritage and tradition. There is no better way to experience the country's vibrant capital, Ljubljana than by relaxing with a coffee along the leafy banks of the River Ljubljanica, which flows through its heart.

## Culture, history and architecture

Jože Plečnik, the master of early-modern minimalist architectural design, graced Ljubljana with many beautiful buildings, and today these buildings house some of the country's finest cultural institutions including the National Museum of Slovenia, the Museum of Architecture and Design and the National Opera and Ballet Theatre. This is also a city

for shoppers, with many stylish boutiques and markets directly overlooking the river.

Maribor, the nation's second-largest city, has just a fraction of the population of the capital. The charming Old Town sits beside the Drava River and buzzes with cafes, while cobbled streets hide a surprising number of museums and art galleries as well as the oldest grape vine in the world.



Old Vine, Maribor



Bled



Logar Valley



[www.slovenia.info](http://www.slovenia.info)  
#ifeelsLOVEnia

Soča River



Ljubljana

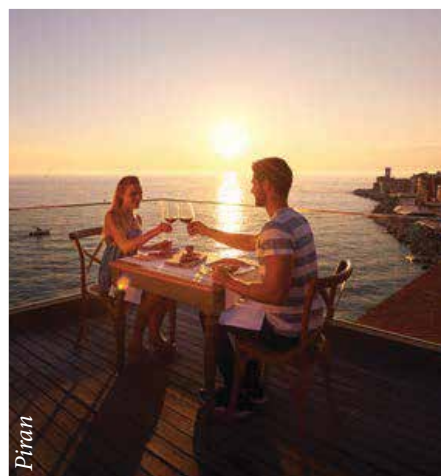

Piran

### Culinary experts and world-class wine

Slovenian winemaking tradition goes back centuries. The fertile soil accommodates 52 varieties of vine including the country's own 'Teran', a full bodied wine grown from the rich red soils of the Karst region. The country is also home to a pioneering orange wine, a floral, honey-colored variety unique to the Goriška Brda region. The Vipava Valley, one of Slovenia's most prominent wine growing areas, is just an hour's drive from Ljubljana. Then there's the food.

Bordering Italy, Austria and Hungary, Slovenia borrows a little something from each of its neighbors, marrying Mediterranean and Central European flavors while also adding a unique twist using its own fresh, locally sourced produce.

Traditional Slovenian delicacies include Carnolian sausage and zlikrofi dumplings, while fresh fish and seafood is widely available in coastal restaurants, such as those lining the Prešeren Embankment in Piran, an unspoiled medieval town on the Adriatic coast. Those with a sweet tooth

should seek out local specialties such as potica nut roll or the decadent and multilayered gibanica cake from Slovenia's easternmost province.

This is also a country on the frontline of world cuisine - Ana Ros, named World's Best Female Chef 2017, is one of Slovenia's finest chefs, creating culinary masterpieces in an inviting country house hidden away in the winding Soča Valley.

### Natural spas and healing waters

It is the quality of the water that Slovenia has to thank for the fertility

of the landscape. The country is home to some of Europe's finest natural spas and thermal springs, with a centuries-old cultural tradition of treating both body and spirit using world-famous magnesium and calcium-rich waters.

---

**For more information about Slovenia, please visit**

**[www.slovenia.info](http://www.slovenia.info) or write us at [sales@slovenia.info](mailto:sales@slovenia.info).**

---



Photo: Terme Krka

# Health and Wellbeing

**Top-class cuisine, top-class tourist offer and top health care.  
From food products to remedies for body and soul.**

Even the most demanding guests will find something for themselves in Slovenia. Nature has provided an excellent basis, which different providers have successfully upgraded – from a prestigious five-star hotel to a museum of eavesdropping and luxury glamping. No matter what your definition of luxury is, you can find what you are looking for.

Naturally, domestic and high quality are the principles that are followed in the food industry. The emphasis is on importance of eating only the best foods; therefore the products they put on the market follow the trends set by health food. Customers all over the world have recognized their quality. Thus old

cereals are coming back and the number of products completely free of additives is increasing.

Slovene pharmaceutical giants are present on the world market with their products. They have developed new medicines, which will significantly contribute to improving the lives of millions of people.

# Land of Verdant Luxury

**Would you like to spend your vacation at a five-star hotel delighting in excellent gastronomy and being pampered in a luxurious spa? Or would you prefer to be in the embrace of nature, enjoying activities and adventure in the great outdoors? Slovenia offers you both.**

*Andreja Lončar*

»The term luxury is acquiring new meaning in tourism. Traditionally there are classic five-star services for the wealthy, gourmet cuisine and premium facilities; these days, however, and in the context of sustainable tourism, luxury may refer to freedom and activity in pristine nature,« remarks Ana Praprotnik, Marketing Director at Sava Hotels & Resorts.

»Luxury in our industry is being intensely redefined, and there is movement away from the five-star to more simple close-to-nature experiences. In this case luxury refers to freedom, the natural and authentic, distinctive local experiences that enhance and promote mental and physical wellbeing.«

According to Ana Praprotnik, such vacation experiences are particularly popular with those whose everyday working lives are very intense and demanding, and who want to spend their holidays actively nurturing their body and spirit whilst enjoying quality time with their families or friends.

Saša Zor, of InterContinental Ljubljana, is of a similar opinion, remarking that those who are willing to spend most for their stay are generally of a more adventurous spirit and seek an authentic experience.

So, what does Slovenia offer such guests?

## **New in Ljubljana: Gourmet Dining and Panoramic Views From the Capital's Tallest Hotel**

»In Slovenia it's a mere hour's drive from the Alps to the Mediterranean, this land is able to offer visitors everything from unsurpassed scenery to quality tap water and the highest level of personal safety,« asserts Saša Zor, Director of Sales and Marketing at the newly opened InterContinental Ljubljana, the Slovene capital's only five-star hotel.

You can soothe your cares away at the 18<sup>th</sup> floor spa of this the most recent addition to the InterContinental Hotels chain. »Whilst taking in views of Ljubljana Castle our guests can enjoy a length or two in the indoor pool, relish a glass of champagne or surrender to the healing hands of professional masseurs,« remarks Zor. Guests dining in style on the rooftop restaurant can relish a meal from a menu devised by Alfredo Russo, chef at the Michelin star restaurant Dolce Stil Novo in Turin, Italy. Alfredo brings Italian charm and exquisite seasonal cuisine from fresh local ingredients to the B restaurant, named in honour of the famous Carniolian bee.

The new hotel balances international standards and expertise with local authenticity, safety and

»Guests dining in style on the rooftop B restaurant, named in honour of the Carniolian bee, can enjoy a menu devised by Michelin star chef Alfredo Russo. Alfredo brings Italian charm and exquisite seasonal cuisine using fresh local ingredients.«

*Saša Zor,  
InterContinental  
Ljubljana*



Photo: InterContinental Ljubljana

comfort. In Saša Zor's opinion Slovenia can - due to its diversity - cater for any taste and desire: from active, adrenaline packed adventures to the discovery of local cultural, culinary and vinicultural specialities. A concierge team at the InterContinental Ljubljana organizes custom city tours for guests, shares insider

information about Slovenia's historic capital as well as arranges any number of visits and excursions; indeed, everything from agro-tourism to a round of golf.

»The Postojna Cave Park is adding some new attractions, such as night visits to Predjama Castle, dining in the dark and ghost hunting. These new adrenaline-inducing attractions are targeted at those who are looking for something new and special.«

*Sabina Paternost,  
Postojnska Jama*



Photo: Postojnska Jama

#### **A Museum of Eavesdropping in Postojna**

Postojna is renowned for its extensive karstic cave system, including the world famous Postojna Cave with its unique olm, the so-called human fish. Several dozen metres from the Cave's main entrance stands the newly renovated four-star Hotel Jama. Superior accommodation is matched with fine dining and an appreciation of the guest, which is also exhibited in the provision of precious gold cutlery upon request.

In addition to regular tours of the cave, specialist tours have been designed for those who would like to experience the more demanding passages and revive the spirit of exploration. Adventure tours are undertaken in small groups led by an experienced guide. »With suitable equipment the adventurers can visit those parts of the cave which are not open to regular visitors; it is an opportunity to practice some caving skills and get a primal experience of a mysterious and unspoiled subterranean world,« declares Sabina Paternost, Public Relations Development Manager at Postojnska Jama.

Such an experience is truly unique and special. »Most find their first cave visit quite a primordial experience, while any such genuine adventure is nicely complemented by some exquisite cuisine and luxury accommodation,« affirms Paternost.

»The Postojna Cave Park is adding some new attractions, such as night visits to Predjama Castle, dining in the dark, and ghost hunting. These are aimed at those who are looking for something new and special, as well as an adrenaline experience,« declares Sabina Paternost. A secret room was discovered during the 2016 renovation of the Hotel Jama. Instituted in the 1970s, during the era of socialist Yugoslavia, the facility was used for listening in on the conversations of guests. It is now being converted into a museum of eavesdropping.

### Riding Lipizzaners in the Triglav National Park

With its picturesque island and Church of the Assumption, Lake Bled is among the most recognizable and popular tourist destinations in Slovenia. Sava Hotels & Resorts' sumptuously elegant Grand Hotel Toplice offers traditional style, comfort and gastronomy. It also features a private lakeside beach and boathouse, as well as a thermal swimming pool and selected wellness services.

Bled is also making a name for itself in a newly defined luxury - glamping holidays. »Glamping

»Set in the bosom of the Alps, Bled is a perfect location for hikes in the surrounding mountains, which offer breath-taking views of the lake. In an evocation of the spa tradition established here by Arnold Rikli back in the late-19<sup>th</sup> century, one can enjoy a stroll around the lake; take a wooden boat and a picnic to the island; savour Bled's traditional custard cream slice at the Hotel Park patisserie, which also boasts a most beautiful lakeside vista; swim in the thermal pool at the Grand Hotel Toplice, which stands directly above a spring, is emptied each evening, and freshly refills every morning.«

Ana Praprotnik, Sava Hotels & Resorts

has become a real hit in Europe over recent years; demand at Bled has rocketed and outstrips availability. All the packages for couples and families have been sold out,« proclaims Ana Praprotnik, Marketing Director at Sava Hotels & Resorts.

Glampers and campers at Bled can take part in rafting, river tubing, riding Lipizzaners in the Triglav National Park, hot air ballooning and canyoning. Bled



Photo: Sava Turizem



**A** mighty medieval fortress and an unmistakable symbol of the Slovenian capital kindly invites you for a visit. Take the **funicular railway** for quick and fun access. Experience the unique **blend of old and new**. Take part in a special **Time Machine guided tour**. Listen to the **audioguide in 14 languages**. Taste the **exquisite cuisine**. And don't miss out on our **special rates** for tourist agencies. Experience Ljubljana from a different perspective.

Don't hesitate to contact us: [sales@ljubljana-castle.com](mailto:sales@ljubljana-castle.com)  
[www.ljubljana-castle.com](http://www.ljubljana-castle.com)



is an excellent starting point for hiking the Alps, and also offers scuba diving in the lake. »People often wrongly assume that guests with a higher purchasing power only desire expensive luxury services; our experience indicates they much more appreciate details and originality,« observes Praprotnik.

With an eye to detail and a unique local narrative, Sava Hotels & Resorts gave their four-star Golf Hotel a complete make-over, bringing to life the spa tradition initiated by Swiss hydropath Arnold Rikli. »Rikli recognised the advantages of Bled back in the 19th century; indeed, its sunny alpine climate and prolonged swimming season put the burgeoning resort on the European spa map,« explains Ana Praprotnik. The creatively renovated Golf Hotel emphasises luxury with sustainability.

#### **A Massage for Two on the Slovene Riviera**

Istrabenz Turizem's six LifeClass hotels - the five-star Hotel Slovenija, together with the four-star Grand Hotel Portorož, Hotel Riviera, Hotel Apollo, Hotel Mirna and Hotel Neptun - are all located in Portorož, the most famous resort on Slovenia's Adriatic Coast.

»Our hotels offer prestigious wellness and weight loss packages,« asserts Anja Kovačič of LifeClass, adding that they actively support local producers of meat, fruit, vegetables and dairy products, even jams, herbs and sea-salt.

LifeClass hotels also offer high quality massage therapies and beauty treatments. In 2017 alone, masseurs at LifeClass spas provided 42,000 massages, ranging from Thai and Ayurvedic, to brine and salt massages using salt from the nearby Sečovlje Salt Pans, there are even massages for couples.

This year LifeClass renovated a pier and a five-star private beach at Portorož. According to Kovačič, among the many attractions is the possibility of a sunset cruise along the coast, accompanied by fine food and a bottle of prestigious champagne. Some guests enjoy a trip along the Italian coast; Austrians, in particular, take panoramic flights over the region, while guests from Russia prefer to take the high-speed ferry for a day's shopping in Venice.

#### **Detox Spas and Health Resorts**

Terme Krka's resorts include the Dolenjske Toplice and Šmarješke Toplice spas, as well as the Šport Otočec and Grad Otočec hotels, the latter housed in a Slovene castle, together with the Krka Hotel in the southern town of Novo Mesto. The Talaso Strunjan, climatic health resort and thalassotherapy centre in Strunjan on the Slovene coast, is also part of the Terme Krka group.

A tradition of spa packages, pampering, relaxation, short breaks and health tourism form a common thread across Terme Krka resorts. »We were the first in Slovenia to institute medical wellness programmes with the aim of improving quality of life as well as preventing and countering lifestyle diseases,« declares Andreja Zidarič of Terme Krka's PR department. In addition to spa packages, Terme Krka offer their guests healthy gastronomy, an ever growing number of sports activities, with a special focus on tennis and golf, as well as congress tourism facilities.

The more demanding local and foreign guests particularly appreciate the Otočec Castle Hotel, the Hotel Balnea at Dolenjske Toplice spa, as well as medical detox and weight-loss programmes provided

»Many of our guests, in search of specific local attractions, take a sunset boat-trip along the coast, this cruise is accompanied by fine food and a bottle of prestigious champagne.«

Anja Kovačič,  
LifeClass Hotels



Photo: LifeClass



by Šmarješke Toplice's Vitarium Spa & Clinique, affirms Zidarič. Offering excellent cuisine and catering for weddings and business meetings, the five-star Hotel Grad Otočec has been a member of Relais & Chateaux, a prestige association of mansions and restaurants, since 2010. Close to the hotel, which is most popular with guests from neighbouring states, as well as the USA and Germany, is an excellent 18-hole golf course covering some 75 hectares.

The services and facilities offered by Šmarješke Toplice are particularly attractive to those who seek detox and weight loss programmes. »Physicians, nutritionists and occupational therapists work closely in conjunction with health and wellness experts in the personal provision of counselling and therapeutic programmes tailored to the needs of the individual guest. Suited to every individual's body, habits and way of life, the type and intensity of exercises help guests achieve the goals established with their mentors at the beginning of the programme; even the menus are personalized, devised to meet the guest's specific preferences and requirements.«



Photo: Terme Krka

»More than one thousand people a year choose a detox or weight-loss programme at the Šmarješke Toplice spa. Physicians, together with a variety of experts and therapists, closely co-operate in the provision of tailor-made programmes, providing counselling and encouragement to each and every guest.«

Andreja Zidarič,  
Terme Krka

## The Škocjan Caves Park

**Škocjan Caves Regional Park** is situated in the heart of Classical Karst where explorers for the first time ever started to discover and explore the karst phenomena. The most beautiful part of the Park is undoubtedly a set of eleven caves, collapsed dolines, ponors and natural bridges known as the Škocjan Caves. They are the most important underground phenomena of the Karst and on the opinion of international experts one of the most beautiful pearls on Earth. Therefore are since 1986 listed on **UNESCO's World Heritage List** and are one of only two Slovenian sites on the list as natural heritage. Caves are also on the Ramsar Convention list (1999) as the first underground wetland and in Unesco's Man and Biosphere (MAB) (2004) research program.

In the Park you can visit famous Škocjan Caves, also the Mahorčič and Marinič cave with Mala dolina, museum collections (Collection of Cave Explorations, biological, geological, archeological and ethnological collections) or follow the marked Educational trail.



Park *Škocjanske jame,*  
*Slovenija*

### Park Škocjanske jame, Slovenija

Škocjan 2, 6215 Divača  
T.: ++386 (0)5 708 21 10  
++386 (0)5 708 21 04  
F: ++386 (0)5 708 21 05  
E: psj.info@psj.gov.si  
www.park-skocjanske-jame.si





**BLEJSKI  
GRAD**  
BLED CASTLE



BLED CASTLE - A MEDIEVAL CASTLE, BUILT ON THE TOP OF A 130-METER HIGH ROCK, FEATURES ITS OWN MUSEUM, PRINTING WORKS, WINE CELLAR, FORGE AND RESTAURANT, AND OFFERS SPECTACULAR VIEWS OF THE SURROUNDINGS. IN SUMMER, THE CASTLE HOSTS A VARIETY OF EVENTS.



Medals for  
Quality.



Perutnina Ptuj

# Most awarded quality comes from Ptuj

5x



1x



22x



18x



10x

Gold Medal  
for Market Range

7x

Silver Medal  
for Market Range

- Innovation Award
- Award for Fresh Meat Market Range
- Special Award in 2017

[www.perutnina.com](http://www.perutnina.com)

Assessment by the Expert Assessment Committee of AGRA FAIR 2017.





Photo: Žito

## Bread Exported to China, Mackerel in Demand in the USA

**The Žito Group, since 2015 part of the Podravka Group, is setting up centralized tea production for the Podravka Group. Don Don has opened a modern plant for the production of toast bread in Kragujevac, Serbia, which will supply the Balkan markets. The Slovene food industry is achieving success with healthy prepared foods.**

*Andreja Lončar*

**»We want to strengthen our presence in Germany, Sweden, and the USA, where demand is strong especially for Delamaris products.«**

*Petra Skok, Pivka Perutninarstvo*

In its desire to expand to foreign markets, the Slovene food industry has been investing in modernization and new production lines. This year the Žito Group set up a new pasta production line and is currently setting up centralized tea production for the whole Podravka Group at its plant at Gradišče near the border with Croatia.

Don Don has just started production of toast bread at the new modern plant in Kragujevac, the company's new regional strategic centre for toast bread production and export.

### **Spelt, Buckwheat and Quinoa Are »In«**

Health food has been setting strong trends and determining aspects of the development of food industry companies for years now. »While developing new products we follow trends towards an increase in the natural content of functional ingredients such as fibre, minerals, higher protein content,« says Matjaž M. Dremelj, Head of the export division at Žito. »We are going back to using old cereals and pseudo cereals, such as spelt, and some other old types of wheat, buckwheat, quinoa, and amaranth. We are introducing legumes and products made from ecologically grown ingredients. We've been reducing the use of allergenic substances and following the trends in

### Slovenia Export More Food Than Food Giant Italy

In 2015 the Slovene food industry made one fourth of its 2 billion in revenue in exports abroad, which in terms of proportion of food exports places Slovenia side by side with big food producers. Italy, for instance, exported 21.9 percent of food sales in 2015 (28.9 billion out of total 132 billion euros of revenues made by food companies).

health food production, which demands lower sugar and salt intake.«

Žito develops products with improved nutritional value within the European Food4Future project, which Žito joined along with 15 other partners. »Food4Future was launched in September last year and will continue for four years. Strudel dough made from spelt flour is our latest innovative product. Spelt has a very balanced composition and is becoming increasingly popular with consumers in Slovenia and abroad,« adds Dremelj.

### Don Don's Bread for Sport Enthusiasts

It is similar at the Don Don Group, owner of the popular brands Tvojih pet minut and Pekarna Grosuplje. Maja Maroša, Head of their marketing division, mentions that Don Don introduced two new types of bread in 2017: the first one being the mixed-seed bread Sosed, produced on the basis of a new and improved recipe and with a higher pumpkin seed content, the second being Protein Bread, which has been awarded the »source of protein« nutrition claim.

»Protein represents more than 17 percent of the energy value of this new bread. Our Protein Bread is particularly made for active sports enthusiasts. Protein intake has a beneficial effect on muscle mass and bone,« says Maroša.

### Healthy Prepared Dishes

It is the development policy of the poultry meat processor Pivka Perutninarstvo to follow the demand for prepared healthy dishes. Pivka Perutninarstvo owns the Pivka brand of poultry products and the Delamaris brand of fish products.

The main Delamaris product is prepared mackerel salads, using a fish rich in healthy omega 3 fats. The company currently plans to widen its product portfolio with new flavours of mackerel and tuna salads, as well as mussels.

Pivka Perutninarstvo poultry dishes are available seasoned and in the roasting pan, prepared to be grilled or roasted. Pivka Perutninarstvo is the proud owner of high quality certificates for chicken products with omega 3 fatty acids and the selenium source code.

### Žito Aiming at Non-European Markets

The entire Slovene food industry makes a considerable portion of their sales in foreign markets. In 2016 Žito, since 2015 a part of the Croatian Podravka Group, made one fifth of its sales abroad (around 25 million euros). »This is almost a 12-percent increase. This year, too, we expect a two-digit growth in sales,« says Dremelj.

Žito's strongest exports are pre-baked bakery products. »These are high-quality breads, which are kneaded, partially baked and then deeply frozen by Žito bakers in Slovenia. They are then shipped abroad where they are rapidly and simply baked to perfection on site in shops and petrol stations. Our bestselling pre-baked product is buckwheat bread with walnuts,« further explains Dremelj.

Žito makes two thirds of its sales in Europe; its largest markets are Italy, Germany, Spain and Austria. In the future the group wants to expand to non-European markets. »We expect an important rise in exports to China, Russia, North America and Canada,« says Dremelj.

### The Don Don Group With the Largest Toast Bread Production Plant in SE Europe

In 2016 the Don Don Group had nearly 90 million euros in revenue; in 2017 the company expects to exceed this figure. Apart from Slovenia, the company operates in Serbia, Bosnia and Herzegovina, Montenegro, Bulgaria and Croatia, and is about to enter the markets in Romania and Albania.

Don Don employs around 2,700 people, 1,900 of them in Serbia, where the group has eight plants. In Kragujevac, it has just opened the largest toast bread plant in SE Europe. The plant is to supply toast bread to Slovenia, Croatia, Bosnia Herzegovina, Montenegro, Bulgaria and Greece,« says Maja Maroša.

»The new toasted bread plant in Kragujevac is the company's new regional strategic centre for toasted bread production and export.«

Maja Maroša, Don Don



Photo: Don Don

### Demand for Delamaris Fish in the USA

Last year, the Pivka Perutninarstvo Group had 52 million euros in revenues. The group's exports – to 20 countries worldwide – showed a ten percent increase.

Delamaris, its bestselling products being canned mackerel salads and mackerel fillets, exports 59 percent of its products, mostly to Austria, the USA, Australia and Russia.

The export of Pivka's poultry products represent one fifth of all the group's sales. The most popular export item is special chicken salami, followed by roasted chicken breast, pâtés and chicken meat.

»We want to strengthen our presence in Germany, Sweden, and the USA, where demand is strong especially for Delamaris products. We want to offer a wide range of delicacies suitable for all generations,« says Petra Skok, Head of public relations at Pivka Perutninarstvo.

### Perutnina Ptuj With the Poli Hot Dog Entering Foreign Markets

Perutnina Ptuj expanded their Poli brand to hot dogs. From this year, customers in Croatia, Serbia and Bosnia and Herzegovina can also buy Poli hot dogs, with ninety percent poultry meat, which is currently the highest percentage in the hot dog market. Moreover, the company is the leading manufacturer of poultry meat products in south-eastern Europe; it is strengthening export to Austria, Macedonia and Romania, where they have their own retail companies, as well as to the markets of Switzerland, Great



Photo: Depopsitphotos

Britain, Sweden and Italy. Recently the company has also worked toward penetrating new markets of the Middle East.

Perutnina Ptuj has developed a new picnic line, employing carefully controlled technological procedures which allow them to attain the desired shelf-life and quality of products with natural spices and aromas. Meat delicacies for the grill are thus available completely free of additives.

The company increased the exports of its products to Austria. What the consumers like best is the fresh chicken meat, conveniently available. Since February 2017, consumers in Austria have been able to enjoy meat from chicken-friendly breeding, which is a best-seller.

At the fair Agra 2017, the company received 32 gold and 25 silver medals for their products. Perutnina Ptuj was awarded the largest number of prestigious medals in the category of new products and thereby also special recognition for their spirit of innovation.

»We are going back to using old cereals and pseudo cereals, such as spelt, and some other old types of wheat, buckwheat, quinoa, and amaranth. We are introducing legumes and products made from ecologically grown ingredients.«

Matjaž M. Dremelj, Žito



Photo: Perutnina Ptuj



# Grill



\* Source: Nielsen 2015

# Delicious and healthy fish delights in 23 countries worldwide

**Due to an increasingly active lifestyle, it has become a challenge during the working week to find the time to prepare wholesome snacks or healthy dinners. Delamaris' delicious and ready-to-eat products are a practical and healthy solution. All Delamaris products follow the latest food preparation guidelines and can already be bought in 23 countries worldwide.**

## **A healthy snack always at your fingertips**

Today, nutritionists have found that we need a daily intake of 250mg of Omega 3 fatty acids for maintaining our cardiovascular health, regulate our blood pressure and assist our brain development. Rich natural sources of Omega 3 are mackerel, sardines, salmon and tuna. The Slovenian company Delamaris has brought together the knowledge of many nutritionists and has developed an excellent range of ready-to-eat products that contain fish, sauces, and more than seven types of vegetables and are gluten-free. The range includes a wide variety of mackerel fillets, mackerel with vegetables, sardines, tuna with vegetables, mussels, anchovies and pates made from various types of fish and flavours. The ready-prepared fish products packed in aluminium BPA free cans with a high recycling rate are a great solution for everyone who understands the importance of a healthy diet. Despite being completely additive-free, the product freshness has been extended from 3 to 5 years thanks to the packaging sterilisation and hermetic sealing. They are great for breakfast, standalone meals on the go or as one of the ingredients when cooking. Now the consumer can take the time for them whilst enjoying their chosen dish.

## **A synonym for excellent quality for nearly 140 years**

Delamaris continues its rich tradition of preserved food preparation, which dates back to 1879. After successfully completing a packaging revamp, this year has seen the expansion of the gluten-free, no



A 125g portion of Delamaris mackerel is enough for half of your required daily intake of Omega 3 fatty acids needed for regular cardiovascular functioning.

additives or flavour enhancers preserved fish product range. The new innovative products complement our traditional range which has enjoyed sales success on various markets for many years.

Delamaris is part of the Pivka group, with its headquarters and production in Slovenia (EU), as well as distribution companies in Croatia and Serbia, it brings together 500 employees. The main activity is the production and processing of chicken meat for the Pivka and Njami brands and the preparation of Delamaris fish products, which provide the active consumer with culinary pleasure whilst saving them time. High quality is confirmed by numerous certificates and medals at annual international assessments of quality, safety, traceability and achievement of superior results in the taste and composition of products, among which are three national certificates for higher quality; the Halal certificate, the Russian EAC (former PCT), the American FDA, the HACCP system, ISO 9001 quality certificate and ISO 14001 environmental management certificate and International Food Standard.

The foundations of success are in-house experts who understand the consumer and trends, first-rate suppliers and efficient process management with respect to the highest production and business standards. Delamaris focuses on the development of

products with higher added value for the consumer and ensures the convenience and perfection of products and accompanying services. It exports its products to more than 20 countries in Europe and Russia, Australia and the USA, and creates revenue of over 50 million euros a year.

## **Reinforcement on international markets and openness for new partnerships**

The future challenges for Delamaris are expanding and strengthening markets. Therefore, the company is looking for experienced and reliable distributors, agents and traders. The aim is to strengthen the market position for natural and healthy ready to eat fish products in numerous countries, with priority given to Australia, the USA, China, Russia, Sweden, Switzerland, the Czech Republic, France and Kosovo. Delamaris understands that there is strength in co-operation and therefore want to build on their operations abroad.

Your interest in co-operation or for any additional information, openly express to Head of International Sales, Nataša Matjašec on +386 5 70 32 078 or by email on [natasa.matjasec@pivkap.si](mailto:natasa.matjasec@pivkap.si). More information on: [www.delamaris.eu](http://www.delamaris.eu).





**Mercator-Emba**  
Proizvodnja hrane d.d.

# TRUSTWORTHY QUALITY

Mercator-Emba d.d. has been for over 60 years successfully producing cocoa instant agglomerated products, dessert toppings, and fruit preparations, as well as other food products. With constant investments into knowledge and development, and with the completion of brand new production plant, we became one of the leading producers, and also established ourselves as a highly ranked and reliable suppliers for even the largest global companies.



In this segment, we provide various dessert toppings – based on fruits, chocolate, or caramel – that represent an important resource for the ice cream and bakery industry. The certificates successfully obtained each year are a clear assurance that the quality of our products and services always comes first.



## ISO 9001

Certifies that we fulfil both the criteria of same food production under the HACCP system and the strictest criteria of good production and hygienic practices.

## UTZ

Obtained in 2014, it refers to a system of sustainable supply of cocoa products.

## IFS

A certificate that ensures good production and hygienic practices, and thereby the appropriate safety of our products.

## SQMS

A certificate required by McDonald's, it certifies that, as their supplier of food product, we achieve all quality criteria.

**PRIVATE LABEL**



For many years, numerous renowned European retailers recognise us a reliable business partner, who can be entrusted with the manufacturing of products.

**OUR LEADING BRANDS**

**CONTACT**

### DARJA JAMNIK

Director of Commercial Division

✉ darja.jamnik@mercator-emba.si

☎ + 386 1 759 84 00

### MERCATOR EMBA d.d.

Tržaška cesta 2c, 1370 Logatec  
Slovenija EU



### BENQUICK

Hot chocolate & Instant Mixes



### SLADKI GREH

Dessert toppings

# New Pharmaceuticals for Diabetes and Cardiovascular Disease

**The largest proportion of the sales of Slovenia's pharmaceutical giants Lek and Krka are accomplished in relation to the treatment of cardiovascular diseases. Indeed, over the past year, both companies have brought new cardiovascular medicines to the market. In addition, Krka has launched innovative drugs for the treatment of HIV and diabetes, whilst Lek has developed new systemic medicines for infections and diseases of the nervous system.**

*Andreja Lončar*

**Pharmaceuticals for the treatment of cardiovascular disease represent 47 percent of Krka's revenues.**

This past year the Novo Mesto based pharmaceutical multinational Krka has registered nine new products in 17 variant forms and strengths. The company has also increased its presence on European markets in a key group of pharmaceuticals for the treatment of cardiovascular diseases as well as with a film-coated emtricitabine and disoproxil combination for the treatment of HIV.

Krka has also registered two oral pharmaceuticals for the treatment of erectile dysfunction in men, a new analgesic for the alleviation of moderate to severe pain, and a new strength of a pharmaceutical used for the treatment of depression, generalized anxiety disorder and diabetic neuropathy. The new

strength of this drug facilitates the use of a single capsule where larger dosages are required, ensuring easier application for the patient.

Lek is marketing new pharmaceuticals and new forms for the systemic treatment of infection, diseases of the nervous, respiratory and cardiovascular systems, as well as disorders of the skin and kidneys.

## **Probiotics and Mineral Supplements**

Both Lek and Krka are reinforcing their non-prescription products segment. Lek is also marketing new forms of its existing pharmaceuticals as well as a range of probiotics.

Krka has registered two new food supplements, one with magnesium and the other with vitamin B2. In 12 European countries, Krka has obtained market authorisation for a new form of pharmaceutical in the treatment of chronic venous insufficiency (CVI) in adults, and the symptomatic treatment of haemorrhoids in adults.

## **Veterinary Health**

While Lek has disposed of its animal health product division to ensure a greater focus on human medicine, Krka is increasing its veterinary medicines business and these now account for some five percent of the group's total sales. Animal husbandry (livestock) pharmaceuticals represents roughly one half of this business, with the other half deriving from pet healthcare products. Krka's largest markets in this sector are Russia, France and Germany.



Photo: Krka

In 2017 Krka obtained market approval in 22 European countries for its anti-parasitic medication for the control and treatment of gastrointestinal parasite infections in cats. In addition to extending its range of livestock veterinary products, Krka has obtained market authorization in Kazakhstan for a highly effective protection against coccidiosis in poultry.

### Krka to Launch Joint Venture in China

While Lek's parent company Novartis has opened the doors to Lek products in over 160 markets, Lek does not - in accordance with group policy - disclose which are its most important markets. Krka, which is present in 70 national markets, focuses primarily on Europe. As regards Central Europe, Krka achieves its best results in Poland, while in Western Europe the group is attaining its highest volumes of sales ever in Germany, France and Spain. Krka announced in September that it will have a majority stake in a Chinese joint venture. The Chinese company is said to be a small pharmaceutical company which has sales of less than 10 million euros a year.

Eastern Europe, and predominantly Russia, remains Krka's most important market and accounts for one-third of total sales. Krka also has a production facility in in Russia where it has some two thousand employees. This plant produces two-thirds of Krka's products destined for the Russian market, and enjoys the status of a domestic manufacturer. This gives Krka competitive advantage, as Russia's government gives priority to Russian manufacturers in servicing the requirements of its health sector. Russia's 2011 strategy anticipates that by 2020 the country will be 90 percent self-sufficient regarding the most important categories of pharmaceuticals.

### Krka's Focus on Cardiovascular Medicines

Prescription medicines are Krka's core business, and account for over eighty percent of its sales; its largest markets are Russia, Poland and Germany. Pharmaceuticals for the treatment of cardiovascular disease represent almost half of the company's prescription pharmaceuticals sales, followed by products for the treatment of diseases of the central nervous system (more than 20 percent), alimentary tract and metabolism (over 16 percent) and infections (over 5 percent).

Non-prescription medicines represent some 10 percent of Krka's sales; its largest markets are Russia, the Ukraine and Slovenia, while animal health products represent 5 percent of total sales.

### Non-prescription Medicines Account for One-third of Lek's Sales

Lek generates some two-thirds of its revenues from prescription pharmaceuticals, with cardiovascular disease treatments representing 25 percent of sales, nervous system (22 percent), and infections (16 percent). In 2016 non-prescription products



Photo: lek

accounted for 31 percent of its business, up 2.5 percentage points in five years.

Indeed, Lek's total sales have grown well over the past five years consequent to its development of new drugs that treat diseases of the blood and blood-forming organs, as well as the nervous and respiratory systems.

### The Challenges of Demography and New Technologies

According to Krka, one of the greatest coming challenges for the pharmaceutical industry is posed by demography: an aging population in developed countries and an increasing number of emergent wealthy nations, with moderate purchasing powers and a majority of the population under fifty.

Other challenges include the rising prices of raw materials, food and energy, increasingly organized virtual interest groups and medical informatisation.

New technologies are also becoming increasingly important in production. Krka is today employing biotechnology and nanotechnology in the preparation of medicines for the treatment of diabetes (recombinant insulins) and autoimmune diseases.

### Billions in Revenues

Both Lek and Krka rank among Slovenia's largest companies and exporters. The Krka group employs some 12,000 people, and its revenues were close to 12 billion euros in 2016. Lek, today a part of the Swiss multinational giant Novartis, employs some 3,600 people in Slovenia and has annual revenues of 1.1 billion euros.

Both companies manufacture generic drugs and generate most of their revenues from prescription pharmaceuticals, though the non-prescription segment is growing. Although veterinary medicines represent a small percentage of Krka's total business, this segment is becoming increasingly important.

**Pharmaceuticals for treatment of cardiovascular disease represent 25 percent of Lek's revenues.**

**Non-prescription products account for 10 percent of Krka's sales.**

**Non-prescription products account for 31 percent of Lek's sales.**

## VALUES ARE THE WAY WE ACT

Professional competence: knowledge, innovation, continuity of learning and changing.

Teamwork: spirit of collaboration, good relationships and sincerity.

Responsibility to everyone.

Environmental sustainability.

Ethic actions and decisions.

Quality and excellence as a guide for everything we do.

**ŠT**ORE **Q**STEEL  
2017 » 2021

[www.store-steel.si](http://www.store-steel.si)



# ELECTROMECHANICAL COMPONENTS

UPON YOUR DEMAND



ELEKTROMAGNETIC AND SENSOR COILS/WINDINGS

PLASTIC PARTS & TOOL MAKING

ASSEMBLY & LOGISTICS

*Everything out of one hand!*

## REPRESENTATIVE DACH

Rodex d.o.o., Steinbeisstrasse 12, DE - 73037 Göppingen  
Mobil: +49 171 830 17 16, Tel: +49 7161 507 07 23  
roman.zitnik@rodex.eu



**RODEX**

SYSTEM SUPPLIER



info@rodex.eu, tel +386 4 28 098 80, fax +386 4 28 098 81, www.rodex.eu



Photo: Bosio

# Car, Motor Bike, Kitchenware: All Carrying the Slovene Imprint

**Slovene producers of specialized materials and equipment meet the highest criteria set by clients in automotive and pharmaceutical industries, the metal casting industry and the coating industry.**

*Andreja Lončar, Barbara Perko*

The Slovene economy's export trends inspire optimism. Between January and July 2017 Slovenia made 16.3 billion euros in exports of merchandise, which is 11.7 percent more than in the same period of the previous year.

Talum and Impol, specialists in aluminium products, and the Helios Group – a member of Global Coatings Group – have for years been among the largest Slovene companies and top exporters. They see even more potential in sales to Slovenia's leading trade partner Germany as well as some other countries that are geographically close to Slovenia.

## **Talum Bets on E-mobility**

Producer of electrolytic aluminium and aluminium alloys, Talum is aiming at producers of electric vehicles. »Our Roll-Bond evaporator panels are designed to be used in battery thermal management systems of electric vehicles,« says Stanko Kores, Senior Development Manager at Talum, adding that the same technology is used in alternative products such as hybrid photovoltaic panels and heat pump evaporators. In primary aluminium production Talum developed a procedure for baking of special graphite

and carbon, thus aiming at the market of electronics for high-speed trains.

Germany accounts for the majority of Talum sales and these are on the rise mostly due to the increased demand of the German automotive industry. »Our castings for engine construction can be found in Volkswagen vehicles. Other partners include renowned brands such as Porsche, McLaren, Bosch, KTM and Husqvarna, to name just a few. We are one of the largest suppliers of pump casings for Mercedes-Benz freight vehicles,« says Kores.

Talum's evaporators are fitted in refrigerators and freezers manufactured by Gorenje, Bosch, Electrolux and Liebherr in Europe and elsewhere. »Owners of WMF, AMC or Zepter cooking vessels might not be aware that our slugs, or more precisely discs, are integrated into the base cores of stainless steel cooking vessels. Indeed, Talum enjoys an 80 percent market share in this segment,« adds Kores.

In 2017 Talum's foundry business unit strengthened cooperation with the Austrian motorcycle manufacturer KTM. While in the past Talum produced hubs and motorcycle forks for KTM, this year they began manufacturing motorcycle subframes for seats as well. Talum has also manufactured oil pan cover for KTM produced by high pressure casting technology.



Photo: Talum

### New Owner Opens up Asian and African Markets for Helios

In March 2017, Helios Coatings Company became part of the global network of the Japan based producer of paint and coatings Kansai Paint. According to Maša Bantan Marot, Project Manager at Helios, through the acquisition the company was given a fresh opportunity to grow and enter new markets in Asia and Africa, where Kansai Paint has a strong presence. »Together with Kansai Altan, Turkey, we plan cooperation in the area of industrial coatings to supply manufacturers of automotive parts and commercial transport,« explains Bantan Marot.

2017 additions to the Helios range include Helios One, a new generation of single-layer coating for the industrial protection of metals. Helios One is a complete, innovative product, enabling the same level of protection as is provided by the usual several-layer coating. The products launched this year include an improved Colomix product range of refinish coatings. Colomix are easy to use, affordable products. Helios is entering the market of concrete construction protection and has introduced new smart epoxy floor systems specialized for the protection and decoration of concrete floors inside and outside, as well as systems for the restoration and repair of load-bearing constructions and plaster.

The company's development policy focuses on the efficiency and functionality of coatings. »The new coatings we develop have a higher level of corrosion protection, allow drying at lower temperatures and

are easy to use and clean.« An important trend in the coatings industry is sustainability and environmental protection; therefore Helios uses raw material from renewable sources for its coatings and polymers.

Helios' major client in terms of sales is the automotive industry, followed by manufacturers of locomotives, trams, buses and electric engines.

As a leading producer in many countries across Europe, Helios also offers the complete range of road marking solutions for each requirement.

**Between January and July 2017 Slovenia made 16.3 billion euros in exports of merchandise, 11.7 percent more than in the same period of 2016.**



Photo: Helios



Photo: Bosio

**A Roller-heat Line Which Can Produce 24 tons of Forged Parts per Day**

Bosio produces heat treatment furnaces, quenching units, manipulators and industrial washing machines which are often part of large production lines or systems, among them manufacturing lines for automobile motors, generators, wind turbines, rotors and more. Among the top products launched in the past year are two which are both the result of Bosio know-how and were developed specifically for the client.

The first product is the automatic continuous roller-heat line for heat treatment (isothermal annealing and normalisation) of forged parts for the globally renowned automotive company Škoda Auto. The line is completely autonomous and automated and operates 24 hours a day, 7 days a week, and is able to process 24 tons of forged parts per day.

The second product is a comprehensive heat treatment line with two chamber furnaces, manipulator and special cooling or quenching unit Quetta from Böhler Bleche GmbH & Co KG (Mürzzuschlag). Quetta was developed exclusively from Bosio expertise especially for this project. The cooling unit has a closed cascade system, which means that all water remains

in the system. Furthermore, Quetta has a cleaning unit, which when the cooling process is finished separates scale or forge cinder from the water, thus ensuring that there is very little waste in the cooling process and ensuring an efficient and ecologically oriented process. The line can process 2,600 tons of material per day.

Their key product scope encompasses comprehensive heat treatment lines, including, but not limited to, heat treatment furnaces, manipulators with load temperatures up to 1,200°C, quenching tanks, sprayers and more. They have developed, manufactured and commissioned heat treatment equipment and technology for some of the world's largest brands, including Siemens, Alstom, Thyssenkrupp, Danfoss, General Motors, Ford, Škoda and others.

Bosio has recently developed, manufactured and supplied a very specific furnace and quenching unit for Larsen & Toubro in India. It is a 25m vertical furnace and sprayer unit for cooling.

They have several new products in development. The most noteworthy is a special manipulator for heavy metal products which can carry them even when they are heated up to 1,100°C. The manipulator can move in all three XYZ directions. They have already manufactured and successfully tested the first prototype and are looking for new partners in Russia, India and within the European Union. Specifically, they are looking for partners in the forgery/foundry industry, metallurgy, machinery and mechanics.

**Technology for the Largest Global Pharmaceutical Companies**

Iskra PIO is a producer of equipment for clean and cleaning technologies, mostly for known clients. Iskra PIO's production range includes safety micro-biological cabinets, isolators, LAF units, equipment for processing of raw materials, clean rooms, ultra-sonic cleaners and aluminium equipment.

»Our Roll-Bond evaporator panels are suitable to be used in battery thermal management systems of electric vehicles.«

Stanko Kores, Talum

»Talum and Fissler have a long common history of about 30 years. As a top quality manufacturer of cookware we need suppliers with high standards like Talum. We believe in and trust on the technical capabilities and reliability of Talum.

Over the years together we have developed a deep partnership. Talum is a very important key supplier of Fissler.«



Photo: Fissler

Dr. Peter Schätzler  
Director Supply Chain Management  
Fissler GmbH



Iskra PIO has more than one hundred partners in Europe and beyond. The company's largest clients are mostly pharmaceutical companies. Iskra PIO's equipment is used in these companies for substance manipulation, protection of technological processes and protection of the environment and people at a very demanding level. Iskra PIO supplies to world pharmaceutical leaders such as Sandoz, Hexal, Salutas, Novartis NEVA, Henkel, Teva, Bosh, Antibiotice, Bayer Pharma, Krka, Lek, Pliva, Belupo, Hemofarm, Alkaloid, Sanolabor, Bosnalijek, Gedeon Richter, Muller, etc.

Iskra PIO manufactures tailor-made equipment to suit individual customers' needs. In the area of handling active substances the company offers first class isolators where the processes take place in hermetically sealed working environments that allow protection of the material, the operator and the surroundings. Iskra PIO developed and patented an isolator for the containment weighing of highly toxic OEB 5 substances. The innovation was given an award by the Chamber of Commerce of Dolenjska and Bela Krajina for the best innovation in 2017. Iskra PIO also received awards for two other innovations: welding tongs for the highest degree security packing of extremely hazardous substances (active pharmaceutical ingredients) and a device for folding of endless bags.



Photo: Iskra PIO

### Trusted by Magna, Renault, Audi, BMW, Peugeot

Toolmaking is the basis of Kovinoplastika Lož technological development. Kovinoplastika Lož Toolshop manufactures highly complex tools for



Photo: Kovinoplastika Lož

forming of sheet metal. Their main clients include Magna, Renault, Audi, BMW and Peugeot. In addition to tool-making, Kovinoplastika provides engineering, active participation in product development and prototyping. The company also provides stamping.

The company has been manufacturing under Kovinotools brand bumper masks for upper price range cars, chassis components, control arms and structure parts made from high strength steel.

The company is currently trying to penetrate the US market with their engineering services and tool making. Apart from North America, the company aims at penetrating South American and Asian markets as well.

### Demand of Automotive Industry Spurs Impol's Foreign Acquisition

The automotive industry is an important client for Impol Group, manufacturer of a wide range of rolled and extruded aluminium products. »Our products are built in vehicles manufactured by prestigious brands such as Mercedes-Benz, BMW, Audi,« says Nina Potočnik of Impol public relations. Over the last

»Our products are built in vehicles manufactured by prestigious brands such as Mercedes-Benz, BMW, Audi.«

*Nina Potočnik, Impol*



Photo: Impol

year Impol was focused on restarting production in a leased bankrupt company in Šibenik. The plant currently employs around 350 people.

Impol-TLM rolled aluminium coils are used in the automotive industry. Impol also engineers alloy upgrades and develops aluminium rods for forging: in fact, Impol is the largest European producer of these rods. The company's largest export markets are Germany, which accounts for more than one third of their sales, and Italy.

**As member of Global Coatings Group, Helios was given a fresh opportunity to grow and enter new markets in Asia and Africa, where Kansai Paint has strong presence.**

### TKK Aims to Sell Its Foam and Sealant Products in Scandinavian and African Countries

TKK Srpenica is engaged in the production of polyurethane foam, silicone, concrete, and coatings. This year it is marketing a new line of adhesives with the brand name Fix Expert. The company's most recognizable products internationally are sealants and polyurethane foam, which they would like to export to African and Scandinavian countries.

TKK Srpenica products have been used in many infrastructure projects in the region. »Our concrete additives have been used in the construction of facilities such as the Črni Kal viaduct, the Markovec tunnel, the Blanca hydroelectric power plant in Slovenia, the March 1<sup>st</sup> tunnel in Bosnia, and the Millennium Bridge in the Montenegrin capital of Podgorica,« reports a company representative.



Photo: TKK



**We supply furniture to retail chains & big contractors.**

**www.ceta.si**



# We manage, you fly



If you have your own aircraft or fleet but don't have an Air Operator Certificate, why not leave the management up to Siavia?

**SI AVIA**  
JET MANAGEMENT

For further information or advice please contact:

SI AVIA d.o.o. \_ Leskoškova 9E \_ 1000 Ljubljana \_ Slovenia

Phone: +38651 353 846 \_ E-mail: [info@siavia.com](mailto:info@siavia.com) \_ [www.siavia.com](http://www.siavia.com)



Photo: Metrel

# World's Leading Producers of Smart Electricity Meters

**Slovene electronics companies address key challenges of the electric power industry: how to provide and maintain electric power quality and how to increase electrical efficiency.**

*Andreja Lončar*

Ensuring good electric power quality is an increasingly important and difficult task for governments, electric power distribution companies and big industrial clients. Changes in supply upset the stability of the entire system.

»In recent years we have witnessed a steep increase in renewable sources and power electronics, both of which cause disturbances in the grid,« says a representative of Iskra, a producer of electrotechnics, further explaining that electric power distribution companies are obligated to monitor quality and report to responsible authorities.

The market for metering instruments is being driven by:

- increasing use of electric energy,
- initiatives for a more effective use of electric power,
- striving for a better quality of power supply and realization that metering is the first step towards its improvement, and
- desire of industrial clients to introduce constant monitoring because of the sensitivity of industrial equipment to grid disturbances.

### Iskra's Analysts in French and German Multinational Corporations

Iskra from Kranj is among those producers of measuring equipment that shape the global market. Iskra has recently launched the new Class A accuracy certified power quality analyzer called the iMC784 Power Quality Analyzer. This product places Iskra side by side with products manufactured by the largest producers of metering equipment, such as Siemens and the French company Schneider Electric.

The target audience for the new analyzer are electric power distribution companies and the industry that strongly depends on high-quality electric power. Iskra's current partners include Alstom, a French multinational company operating worldwide in rail transport markets, and GossenMetrawatt GMC, a German global market leader in measuring and testing equipment. Iskra's strategic markets are the European Union and Russia. »We seek contacts with energy consulting companies and agents with links to local electric power distribution companies which we cannot reach directly,« says Marjana Lavrič.

According to Lavrič, Iskra develops and manufactures metering instruments for smart grids, for monitoring electric power quality and for control of electric power consumption in electric power distribution, industry and buildings. These three areas have been recognized as priority areas by the EU, which (co)finances several Iskra's projects.

### Metrel Widens Its Range of Products for Industrial Environments

Metrel, one of the world's leading manufacturers and suppliers of high quality electrical measurement and test instruments provides solutions for the safety control of electrical installations, machines and appliances.

At the end of 2016, Metrel introduced two new additions to its range: a test instrument intended for transformer testing (Digital Transformer Analyzer MI 3280) and a test instrument intended for the measurement of earth resistance, specific earth resistance and earth potential of various energetic and non-energetic objects (Earth Analyzer MI 3290). »With both these test instruments Metrel is entering totally new markets where the company has never traded. We are widening our range of products for industrial and other demanding environments,« says Bruno Jelenčič, Marketing Director at Metrel.

Metrel's key and most recognizable segment remains the Eurotest family of multifunctional measuring instruments, which the company sells in Australia, China, India, the Middle East as well as in North and South America. The new EurotestXD MI 3155 measuring instrument, representing a new generation of Metrel's multifunctional measuring



Photo: Iskra

EU co-finances several Iskra's projects.

instruments, will strengthen Metrel's leading position among producers of solutions for complete installation safety.

The company, with more than 150 partners in some 70 countries, is seeking new partners in the Middle East, Africa, South and North America.



Photo: Metrel

### Millions of Iskraemeco's Smart Meters for Dutch Households

Iskraemeco follows the trends of increasing informatization of electric power management, the central part of which are smart meters. A former manufacturer of electromechanic meters has become a producer of highly-integrated smart meters as well as communication tools and software for measuring and measurement data management.

Half a million smart meters for Dutch households.



Photo: Iskraemeco

Iskraemeco's latest product is the »Smart grid ready« modular meter AM550, which facilitates an effortless exchange of various communication modules. »The AM550 modular electricity meter enables Iskraemeco to adapt to technical requirements on different markets. With an innovative platform approach it enables the seamless integration of next generation smart metering functions into a smart grid. It enables electric power distribution companies to be prepared for future technological changes and reduces costs of operation and maintenance,« explains Nataša Hartman of Iskraemeco.

In 2015, Iskraemeco signed a contract with four Dutch electricity distribution companies to supply them at least 1.6 million of AM550 modular electricity meters for Dutch households, with the total number estimated to be 2.5 million by the end of the project. In 2017, the company will supply an estimated 0.5 million AM550 modular electricity meters.

### Faster and More Precise Measurements

The optical measuring systems Trames is the latest addition to the Lotrič Metrology range of metrology solutions. Trames measuring systems is adapted to clients' requirements for faster and more accurate measurement of a wide range of products in industry and laboratories. The target audience includes the automotive industry, the electronics industry, plastic manufacturing and machine industry.

The TRAMES system excels in adaptability. The fastening system as well as measurement characteristics – region, precision and resolution – can all be adapted to clients' personal requirements, says a representative of Lotrič Metrology.

In its five-year strategic plan, the company with daughter companies in Croatia, Bosnia and Herzegovina, Serbia, Macedonia and Austria, all with accredited laboratories, identified Austria, Italy and Germany as their central markets.



Photo: Lotrič Metrology

# SHIPPING **THE** FUTURE



CMA CGM SLOVENIJA D.O.O.  
VOJKOVO NABREZJE 30 - 6000 KOPER

Phone: +386 5 6625 360 - Fax: +386 5 6625 361 - Email: [kpe.genmbox@cma-cgm.com](mailto:kpe.genmbox@cma-cgm.com)

[www.cma-cgm.com](http://www.cma-cgm.com)

## CUSTOMS PROCEDURES NON-STOP

# 24/7 All kinds of customs procedures, 365 days a year

Our company, with 25 years' practical experience and a team of 46 professionals in logistics and customs operations, offer the following services:

- All kinds of customs procedures, including single authorisation for simplified procedures (SASP) 24 hours a day, 7 days a week (IM, EX, T1, T2L, etc.)
- Branch offices in Gruškovje/Macelj, Obrežje/Bregana, Port of Koper and Novo mesto
- Organisation of national and international transport (rail, road, sea and air)
- Warehousing. In cooperation with the Port of Koper, we offer warehousing for import, export and transit goods in open and closed spaces within the Port of Koper economic zone.
- Administrative services. Customs and tax representation, organisation of inspection controls, consulting in the classification of goods in the Combined Nomenclature, submission of reports to the EU system INTRASTAT.

### Why RCM d.o.o.?



RCM d.o.o. has obtained the latest ISO 9001:2015 quality management system certificate. ISO 9001 is the world's most widely recognised quality management standard and helps organisations to meet their customers' expectations and needs. As part of the ISO 9001:2015 certification process, RCM, d.o.o. engaged in a rigorous audit of its business processes.



#### Credit excellence, AAA class certificate

RCM d.o.o. is ranked among the top 4.2% of companies in Slovenia and has therefore been given the highest AAA credit rating.



Authorised Economic Operator (AEO) certificate for customs simplifications. **This certificate places the company in a more favourable position when using simplified customs procedures, and presents a lower level of risk in the risk analysis system.** The certificate allows the company to be identified as a safe and reliable partner in international trade and, as a result, to undergo fewer inspections during customs procedures.



We have obtained, from the Customs Office of Slovenia, **authorisation for simplified procedures** regarding customs formalities, which means faster customs procedures.

A **Freight Forwarder** is a Business Partner that **saves money and time.**



## Freight Forwarding to Cut Logistics Costs

### HOW A FREIGHT FORWARDER CAN SAVE YOUR MONEY AND TIME?

Freight Forwarders have access to a network of service providers allowing you to leverage their shipping expertise to benefit the logistics requirements of your business.

Expert knowledge of Freight Forwarders in the domain of tax and customs legislation enables the selection of the optimal customs procedure. **This can dramatically improve your cash flow and delivery time.**

Due to the sheer volume of shipments, a Freight Forwarder can often negotiate better rates with their trusted providers. This allows you to continue shipping as usual, while bringing you greater discounts for the same services.

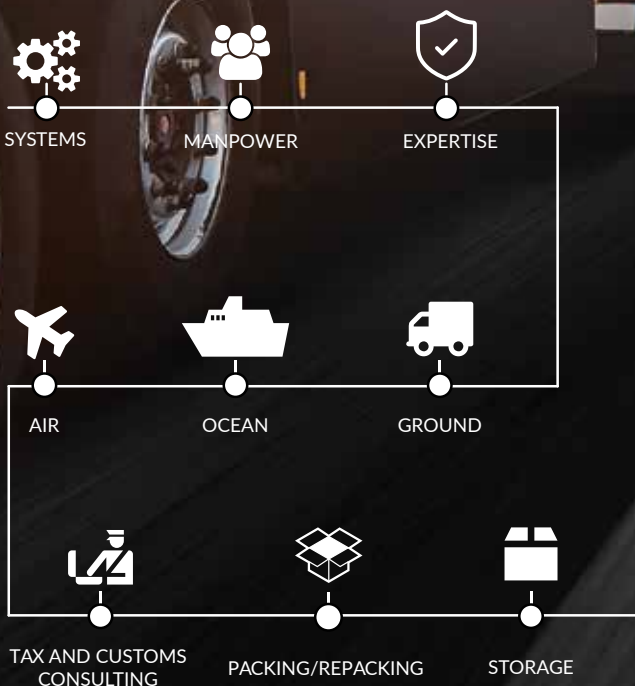

**RCM**  
d.o.o.  
www.rcm.si





# connecting europe



Slovenske železnice  
SŽ-Tovorni promet

e-mail: [cargo@slo-zeleznice.si](mailto:cargo@slo-zeleznice.si)  
Tel.: 00386 01 29 14 280

[www.slo-zeleznice.si](http://www.slo-zeleznice.si)



Photo: Slovenske Železnice

# Projects That Will Benefit Not Only Slovenia But All of Europe

**Slovenia is running projects that will have a positive impact in the wider European region.**

*Barbara Perko*

In the field of logistics, the most important current business trend is the system of »just-in-time« ordering which minimalizes inventory and lowers supply costs. A related business trend is the anticipation of demand strategy that shares the same goal: cost reduction as well as the reduction of resources needed for logistics and transportation operations.

The »just-in-time« principle is also important for the Port of Koper. A wide variety of companies, mostly from the automotive, food, steel, and electronics industry, are supplied through the Port of Koper. Because the port's customers operate according to

the »just-in-time« principle, the productivity of the port and the effective functioning of the entire chain of logistics are also crucial.

The Luka Koper Group is among the most successful in its segment on an international scale, achieving a return on equity of 13.9% in 2016 and a profit margin of 24.7%. The group's results have more than quadrupled in the last three years, a consequence of increased investments in port capacity, which accelerated the growth of throughput. As a result, the port saw an increase in revenues and business results in general.

The largest part of the new investments was aimed at expanding capacity, enabling the port to accommodate 1.3 million TEU of annual throughput by 2020. The arrival of larger container ships will require more moorings, a longer length of coastline dedicated to the port, and additional storage area and equipment. In 2017, the company plans to invest 58 million euros in port infrastructure and equipment.

This year the group acquired new rail mounted gantry cranes (RMG) for the container terminal and a dedicated new multi-purpose warehouse for their use. The implementation of the most important part of the project, the extension of the container terminal, will take place in the future.

### Up to 43 Million Tons of Cargo on a Second Track

One of the most important infrastructure projects in Slovenia, and one which will have a direct impact on the Port of Koper, is the construction of a second railway track from Divača to Koper. The second track plays an important role in both the Slovene economy and the economies of neighbouring countries. The Slovene Ministry of Infrastructure emphasizes that the capacity of transport corridors going through Slovenia will increase, as will the access to the Port of Koper for both Slovene companies and those from neighbouring countries.

The transport capacity on the existing line between Divača and Koper is 17.7 million net tons per year. The second track will increase this by 25.7 million, meaning that it will be possible to transport 43.4 million net tons of cargo annually. The ministry reports that Luka Koper's forecasts anticipate that 35 million tons of cargo will be transhipped through Koper by 2030.

There will be eight tunnels, two viaducts, two bridges, and one gallery on the 27.1 km long route of the second track. The law related to the second track was passed in September by referendum. Because



Photo: Depositphotos

of the referendum, key activities on the project were delayed for several months. Preparatory work is now expected to begin in November this year, and it is anticipated that the project will be completed by the end of 2025.

### Continually Upgrading the Railway Lines

The Ministry of Infrastructure has set as a priority the modernization and upgrading of the Slovene rail system, particularly the main European corridors. This will ensure greater route capacity and transport volume, and reduce travel times and maintenance costs. The modernization of the railway line between Ribnica and Kočevje will be completed next year. In 2019 an additional two projects will be completed: the upgrading of the Pragersko hub and the upgrading of the Poljčane-Slovenska Bistrica line. By 2020, the Zidani most-Celje railway line will be upgraded. By 2023, an ERTMS/ETCS system will be installed at the Dobova-Zidani most, and the Pragersko-Maribor-Šentilj railway sections will be completed.

**The second track will increase the transport capacity on the existing line between Divača and Koper by 25.7 million net tons per year.**



Photo: Slovenske Železnice



Photo: Slovenske železnice

**The Slovene railway operator is rapidly developing a new integrated business system that will enable it to provide transport service more efficiently and quickly.**

### Up to 20 Million Passengers Each Year

The above-mentioned upgrades are of great importance to the Slovene railway operator (SŽ - Slovenian Railways), which already transports enormous amounts of cargo. Last year the rails carried approximately 19.2 million tons of cargo. The main strategic goals of SŽ in passenger and freight transport is as follows: to transport 20 million passengers per year in new modern trains, and to become the most competitive cargo carrier from the North Adriatic ports to Central Europe.

Large companies from all over Europe active in the iron, steel, automotive, energy, agriculture, and manufacturing industries are among SŽ's many business partners. SŽ's freight transport company already operates independently in Austria and Croatia. The company intends to continue strengthening its regional presence by operating independently in foreign markets.

SŽ-VIT traction and technical services is also successful in foreign markets. The company provides

services related to the maintenance of wheelsets, freight wagons, electric and diesel locomotives, and technical-wagon activities.

In the first half of this year, SŽ's international passenger traffic from Slovenia to Hungary increased by 67%, and by roughly 60% in the other direction. Increased passenger traffic has also been recorded on routes to Croatia, Italy, Germany, and Austria.

SŽ anticipates the increased use of combined methods of transportation: »In the next few years, we can expect more intensive cross-border linkages of passenger services, connecting train travel with car sharing and car pool services, and the integration of other forms of transport, train, buses, cars, bicycles, etc.«

One of the most important innovations in SŽ passenger transport is the purchase of modern trains that will begin to run on the Slovene railway network in two years. The company is also rapidly developing a new integrated business system that will enable it to provide transport service more efficiently and quickly.

Printed on the recycled paper Voprint, 80 g, by VPPAP MDEMERŠKO, d. d.



Photo: Depositphotos

### Slovenia's Digital Driver

Four Slovene companies BTC Logistics, ZZI, Mentek and Špica are participating in the Digital Driver project. Digital Driver is a system that will manage transport scheduling, monitoring shipments and the operations of the driver in real time, and providing access to all data via a common communication platform. The system communicates through the ePOD Digital Appliance platform. The driver is able to input data such as the verification of receipt of goods, loading and unloading, damage to packages, ongoing transport and final delivery of shipments. The dispatcher has full control over the location of vehicles, individual shipments, and road conditions. In the case of a breakdown or other failure, another truck can be sent. Customers can monitor shipments, time of service, and other important information.

### The Largest 3D Printing Centre in Southeast and Central Europe

In May, EPPS, owned by Pošta Slovenije, opened the largest 3D printing centre in Southeast and Central Europe. The company offers comprehensive 3D printing services: starting with the concept, 3D-scanning and modelling, and the final product. Companies in various industries – including automotive, tooling, electrical, aviation, defence, medicine and other high-tech companies – are making use of the service. EPPS produces functional prototypes, small-sized final products as well as spare parts, moulds, models and business gifts.



Photo: EPPS

### DARS Is the Icebreaker in Europe

Slovenia will be the first European country to switch from the current system of toll stations with ramps for vehicles with the maximum permissible weight over 3,500 kg where passage is only allowed after toll payment to electronic toll collection with free traffic flow. No European country has yet to install an electronic system for heavy vehicles and raise the ramps. The new programme will make use of a microwave toll system with a standardized frequency of 5.8 GHz. Heavy vehicles will drive through portals above motorways and expressways that will be located along the entire motorway network.

The automated toll collection system is expected to begin test operations in December of this year, and will be fully activated at the latest at the beginning of April 2018. DARS emphasizes that the new system must be functioning perfectly before the old system is switched off. A single day of missed toll collection means a potential loss of more than 600,000 euros.

The number of heavy trucks on Slovene motorways is increasing each year. Data from 2015 indicate that on the busiest sections of the motorway have seen an increase in vehicle traffic of over 7 tons as compared to the previous year. In 2015, in one of the most overburdened sections of the motorway between Ljubljana and Brezovica, the average annual daily turnover of vehicles exceeding 7 tons was 6,950 per day, while the year before it was 6,400 vehicles. This represents an 8.6% increase. A 10.9% increase was also recorded on the western Ljubljana ring road on the Brdo-Kozarje section.

### Three Key Road Projects

The Slovene Ministry of Infrastructure has announced that the Draženci-Gruškovje section of the motorway will be fully completed in the coming year. Two other important projects got the green light. The Ministry of Infrastructure signed a protocol, confirming that the

3rd Development Axis project is a priority of motorway infrastructure planning. Currently, acquisition of land and the generation of project documentation for the construction of the southern and northern parts of the 3rd Development Axis project are underway. The construction of the second tube of the Karavanke tunnel, for which European funds and building permits have already been obtained, will begin soon. It is anticipated that the project will be completed by 2022.

### Pošta Slovenije Entering the Segment for Temperature Sensitive Products

The decline in traditional postal services and their replacement with electronic means of communication have forced Pošta Slovenije (Post of Slovenia) to develop innovative and competitive services. Increased emphasis is placed on services that are tailored to individual clients. For the reason, the Slovene postal service is now present in areas where they were not in the past: for example, the morning delivery of magazines and commodity logistics (appliances, car parts, beverage delivery, etc.). It is also entering the business of delivering temperature sensitive products and medicines. It also provides the service of delivering foods purchased online to final customers at addressees throughout Slovenia at agreed upon time intervals.

The Slovene postal service is following other trends in logistics and transport, specifically delivery-on-demand and 24-hour-a-day, 7-day-a-week delivery. Pošta Slovenije will continue to expand their self-service post offices. Services will be upgraded to include a so-called self-service zone within large post offices and state-of-the-art external self-service PS Point 24/7, where it will be possible to perform postal and banking services and purchase goods.

**Slovenia will be the first European country to install an electronic system for heavy vehicles and raise the ramps. The system will be fully activated at the latest at the beginning of April 2018.**

### Most Charging Stations for Electric Vehicles in Europe

Slovenia is aiming to become one of the reference countries for green mobility, which is also the central vision of SRIP Mobility. In July, the core project EDISON (Eco Driving Innovative Solutions and Networking) was launched. It includes 41 strategic partners, ranging from companies and research institutions to municipalities. Tanja Mohorič, SRIP coordinator, says: »This is a great project for realizing our strategy and placing Slovenia on the European map as a reference country for green mobility.« Slovenia currently has the best coverage with charging stations for electric vehicles in Europe. Because of its size, the country is extremely suitable as a laboratory for green mobility and a testing ground for creating business models that introduce green mobility.

**Slovenia is extremely suitable as a laboratory for green mobility and a testing ground for creating business models that introduce green mobility.**

The EDISON project involves the development of new components, systems, solutions and business models for green mobility. It will be engaged in activities that promote the building of electric charging stations in defined corridors to accelerate electrification, the introduction of green energy sources for the electrification of mobility, and an increase in the purchase of electric cars resulting from the new infrastructure.

In the fall of this year, preparations were made for the Single Window project, which is expected to start in spring 2018. The goal of the project is to connect all logistics providers with relevant state authorities that require data about logistics. In this way, administration related to logistics could be streamlined and delivery times reduced.



Photo: Depositphotos

Outstanding transport services | **Strategic logistics management** | Storage development solutions



**BTC**  
Logistični center

[www.logisticni-center.si](http://www.logisticni-center.si)

BTC Logistics Centre | SI-1533 Ljubljana | 16, Letališka | phone: +386 1 585 11 88 | faks: +386 1 585 10 07 | [logisticni.center@btc.si](mailto:logisticni.center@btc.si)



www.tpg.si

**YOUR BUSINESS.  
MOVING WITH US.**



*Trust, Personal care  
and Global presence.*

## **T.P.G. = Trust, Personal care and Global presence**

TPG Logistics was established and operates under principles which are evident from the very name of the company:

- Trusted by both its partners and customers
- Professional attitude in the quality provision of a personalised service, and
- Global, providing comprehensive world-wide coverage in relation to every requirement, including door-to-door.

TPG Logistics is a dynamic rapidly growing company with proficient staff who have the knowledge and make every effort to provide the best & fastest transport solution. Based on professional experience acquired over a number of years, TPG Logistics offers optimal solutions and competitive rates.

### **Primary Services**

- Organisation of sea freight, air freight, groupage and truck transport
- Storage and distribution of goods
- Import and export with in-house customs clearance by a fully accredited customs agent, turning complicated customs documentation into a hassle-free process
- Provision of consultancy to clients in the attainment of optimal logistics solutions

TPG's subsidiary TPG Agent, offers a vessel chartering facility as well as the possibility to book project and bulk cargo capacities.

TPG also specialises in perishable cargos as well as other temperature-sensitive freight, in which the company also represents one of the largest partners of Luka Koper at the Port of Koper.

### **Advantages of TPG Logistics**

- Offers maximum flexibility, providing customers with quick decisions and rapid responses.
- A successful company with 20% annual growth
- Trusted by an increasing number of customers, whose business is growing with that of TPG
- In relation to container throughput, one of the Slovenia's leading logistics enterprises
- Global presence through its partnerships with logistics service providers world-wide
- Providing excellence, guaranteed through certification:
  - ISO 9001-2008 (Certificate QS-5478)
  - Authorised Economic Operator (AEO Certificate SIAEOCSI001000201131967)



**www.tpg.si**

# Via Koper and Brnik to all corners of the earth

**Interservice, which has been around for 25 years, does business with the whole world via the Port of Koper and Brnik airport.**

Although the company specialises primarily in maritime and air transport, the logistics company Interservice, based in Koper, also provides its customers with road and rail transport options – arranging all customs and inspection formalities as well, of course.

Interservice, the Koper-based logistics company, deals chiefly with maritime and air transport; however, with the help of several partners, it also has a heavy presence in road and rail transport. ‘We will meet your wishes and requirements by searching for the optimal solution for the delivery of goods to the desired destination, by road, sea or air, packed in containers, on pallets, as packages or in bags, even if you only wish to send individual machines. We will look for the best possible options that meet your requirements, at the best price,’ says the company.



## Out into the world via the Port of Koper

The company is present mainly on the markets of the Middle and Far East, which are gravitating towards Koper as their entry point for Central and Eastern Europe. It is also oriented towards other markets in which it sees development opportunities, such as Japan, South America and South Africa.



Vojkovo nabrežje 38, 6000 Koper  
Tel.: ++386(0)5 6633 033  
Email: info@interservice.si  
www.interservice.si

Its operations are carried out via maritime routes that enable it to provide competitive schedules for the transport of goods.

The company takes a holistic approach to dealing with its customers, and can provide them with a comprehensive range of services, from shipping agency services and customs procedures to the inspections required by the Food Safety Administration and delivery to the door.

‘Our company’s goal is to provide every customer with high-quality and competitively priced services, and we also deal with demanding and delicate shipments, all with the highest degree of professionalism. Our calling card is reliability, loyalty, precision and flexibility.’ The quality of the company’s services is attested by an AEO certificate, a triple A creditworthiness certificate and a certificate for the import of organic products.

## Single and aggregate sea containers

For shipments by sea, the company partners with well-established shipowners to offer the best possible solutions for the transport of goods in containers from all over the world, both for imports and exports. The company also offers aggregate containers for smaller shipments. Interservice have several years of experience in transporting

refrigerated and frozen goods, car parts, coffee, electrical materials, waste of different types (brass, metals), textiles, etc.

Air shipments via Brnik airport With the help of its own office at Ljubljana Jože Pučnik Airport, the company also provides its customers with the import and export of air shipments across the world, providing door-to-door services, express shipments and courier services, as well as the transport of hazardous substances and consignments with special status (valuable consignments, perishable goods, etc.). It also arranges all customs and inspection formalities for its customers.

## Comprehensive traceability of goods

Interservice guarantees the comprehensive traceability of goods, with customers being informed of every movement their goods make. This is particularly important for the transport of highly perishable goods. The vehicles used by the company are equipped with a GPS system, which is crucial for providing notice of the arrival of goods at their destination. In order to strengthen its competitiveness, the company is constantly investing in digital procedures and takes an active part in their development.





## EUROPACIFIC GROUP

is a modern international logistics company with a tradition of organizing land, sea and air transport with highly qualified staff. Our competitive advantages are a recognized cooperation with the Port of Koper and its authorization.



### MARITIME TRANSPORT

We organize the transportation of general, project, bulk, liquid and other cargoes for import, export and transit, supported by maritime, land and railway traffic all over the world.



### RAIL TRANSPORT

We organize the transport of goods by rail in all European countries, CIS countries - Association of Independent States, parts of Asia and the Middle East, by renting wagons and containers.



### AIR TRANSPORT

We strive to become one of the leading players in the aviation logistics with the use of many internationally renowned airlines. Any deficiencies in the aviation logistics are resolved with road transport or shipping.



### ROAD TRANSPORT

The speed and reliability of road transport are our priority principles in organizing entire or partial international loads, and we pay special attention to transportation safety and ecological integrity. We are also member of TAPA EMEA network.



### WAREHOUSING & DISTRIBUTION

A major logistics service is also warehousing. For our customers we find a warehouse for different categories of goods, such as food products that require special temperature regimes, dangerous goods, technical goods and other general cargo with the status of customs, local or excise goods.



### CUSTOMS CLEARANCE

Europacific offers comprehensive solutions in the field of preparing customs documentation. We prepare documents for the purpose of import and export customs clearance or the transit of goods. Our business partners are constantly informed about new developments in the field of customs and tax legislation.

SLOVENIA  
SLOVAKIA  
CROATIA  
HUNGARY  
SERBIA

EUROPACIFIC LOGISTIKA D.O.O.  
EUROPACIFIC S.R.O. BRATISLAVA  
EUROPACIFIC RIJEKA D.O.O.  
EUROPACIFIC REPRESENTATION  
EUROPACIFIC LOGISTICS DOO

T: +386-(0)5-6626-380  
T: +421-(0)2-330-069-48  
T: +385-(0)1-7776-204  
T: +36-30-820-7559  
T: +381-21-456-400



Photo: Styler

# Leaving for Vacation Has Never Been so Simple

**A chatbot that helps you find information about ferries, an application that helps you find transportation to airports, programme solutions that optimize your departure, and applications for a healthy life.**

*Barbara Perko, Žiga Kariž*

## **Chatbots for the Ferry Schedule**

The Styler Company has developed an application called Trajekto that shows the schedule for selected ferries to Croatian islands using a basic interaction between the user and a bot. The key advantages of using a chatbot instead of browsing on an internet search engine is considerably shorter search time, a more manageable and user-friendly system, and having all information in one place.

The pilot project will be adapted for the next summer season. The company also has plans to make Trajekto available in English, German, and Italian, and

to present the programme to all tourists who visit the Croatian coast. Styler does not intend to limit itself to neighbouring Croatia. The company has the ambition of developing a universal chatbot for ferries that would be available in countries such as Italy, Greece, France, and Spain.

Styler is developing several new chatbots for Slovene companies that will offer consumers necessary information about specific companies and their products and services—all in one place. By the end of October, the company launched KriptoBot, which provides information about the latest values of more

than a thousand cryptocurrencies. The following are some other products developed by Styler: a chatbot for the Delo newspaper company, a chatbot that sends out current information about conditions on Slovene roads, a chatbot that provides education about Bitcoins and the most recent valuation of other cryptocurrencies.

### Self-Checkout Cashiers in the Stores of South Korea

Thanks to the Mikropis Self Shopping services, consumers in Slovenia can shop in a new and different way. Shoppers can scan articles as they move through the store and pay for their purchase as they leave. Another advance will be the purchasing of items using a mobile phone app, which will also assist shoppers as they navigate through the store.

One of Mikropis's most successful products is the Self-Checkout Cashier, cash registers with touch screens in stores and restaurants, services for mobile payment, marketing, and advertising, mobile loyalty programmes, and other mobile applications. In 2016, Mikropis's self-checkout cashiers were launched on the Chinese market. They were installed in a retail chain in China and are now fully operational in seven stores. The company recently entered a cooperation agreement with E-mart, the largest South Korean retailer, which owns three hundred supermarkets. By the end of 2017, self-checkout cashiers will be introduced in the first three stores.

This year the company entered an official partnership with the Mayo Clinic with its 24alife solution for improving health outcomes. The application includes a number of programmes that contribute to a healthier life style. The TATA conglomerate in India also uses 24alife solutions, and Mikropis is developing a co-operation with Dubai Silicon Oasis.

### GoOpti Alliance with Emirates and Qatar Airlines

GoOpti is developing proprietary solutions for providing mobility to smart communities, and linking with outside partners and digital platforms using programme interfaces. At the beginning of 2017, the company put out a mobile application that made



Photo: Mikropis

it possible for travellers to reserve GoOpti transportation options quickly and easily. The company entered into a partnership with the Amadeus global reservation system that lists approximately 700 airlines, 87,000 hotel accommodations, and 30 of the largest rental car companies from around the world. In the framework of this system, GoOpti plans business combinations with Emirates Airlines, with Qatar Airlines in Italy, and, in Spain, with the Rico bus company from Cadiz. Rico has been present on the Spanish market for more than 50 years.

### NIL Helps Optimize Global Telecommunications

As a systems integrator, NIL is engaged in linking the technologies of different providers into high-efficiency information solutions that provide users with more effective and safer operations, simplify processes, and optimize expenses. In the past year, the company worked on automation and simplifying the management of business networks and information infrastructures.

NIL is active in providing solutions for both users and producers. Among the company's most important partners are the American corporation Cisco and VMware. NIL collaborates with Cisco in the field

**Mikropis entered an official partnership with the Mayo Clinic with its 24alife solution for improving health outcomes.**



Photo: Styler



Photo: NIL

of advanced network technology. In collaboration with VMware, the company is making inroads into the markets of Central Europe in the field of advanced approaches to data centres and computer clouds. NIL is also the leading global partner of the Cisco Company in its training and education programmes.

NIL counts among its customers leading global telecommunication companies such as Orange Business Services, Deutsche Telekom, and Telecom Italia. NIL has assisted these companies in the planning and optimization of their networks through which service is provided to hundreds of millions of users. NIL customers also include leading regional banks, insurers, pharmaceutical companies, medical institutions, universities and global institutions such as the World Bank.

**NIL has assisted Orange Business Services, Deutsche Telekom, and Telecom Italia in the planning and optimization of their networks.**

#### **Adiko Banka, Kolektor, and A1 Use SRC Solutions**

The SRC Company is a provider of the system platform Next, which merges all key systems in one place. Next offers a simple, understandable, and intuitive interface that shows only the data, documents, and functions that users need in their work. It offers users specific information and documents depending on their location. CRM, DMS, and digital banking platforms are used by companies such as Velux, Adiko banka, Kolektor, and A1.

In infrastructure, SRC offers solutions in the fields of communications, data preservation, servers, and integrated solutions for data centres. SRC upgrades the products of its business partners, such as HP, Cisco, Microsoft, IBM, and Palo Alto, with their own services, adapting specified solutions to the needs of individual clients. SRC also designs private clouds and offers cloud services in the form of IaaS and SaaS.

#### **Hilti, Sandoz, and Axalta Use Agitavit's Products**

Agitavit Solutions specialize in business solutions for their partners as well as in the management of products' life cycle, product information systems, 3D modelling, the personalization of products, and solutions in the field of the internet of things. Including in their references are products related to the intranet, portals, project management, advanced analytics, and identity management. The company also offers a series of products called Agitavit eHRM that support human resources processes. Among Agitavit's largest customers are Hilti, Sandoz, Axalta, Bayerische Versorgungskammer. The company also works with A1, GEN-i, Hidria, Kolektor, Krka, and Telekom Slovenije.



Photo: Mikropis

# Our sustainable competitive advantage: **5 technologies at one place**

Iskra ISD is the manufacturer of individual components and assemblies, supplying the automotive and energy industries, as well as manufacturers of household appliances.

With our knowledge, experience and technology we offer our customers a wide range of engineering and production solutions – all in one location.

**Aluminium die casting and CNC machining**



**Injection moulding of thermoplast and thermosets**



**CNC turning and grinding**



**Electroplating**



**Assembly**



Photo: Cleangrad

# From Clean Rooms to Clean Water

**Slovene know-how has convinced even the most demanding consumers in niche segments where quality and knowledge are the most essential.**

*Barbara Perko*

Cleangrad offers the most advanced cleanroom solutions characterized by high quality, flexibility, and long-term reliability. It can supply their customers with both individual and all-round solutions. The company's top-quality products and comprehensive service have impressed the pharmaceutical, health-care, high-tech and food industry.

Toring Turbine is one of the fastest growing water aeration companies in the world which strives to provide the best energy efficient solutions for water, wastewater, and recycling. Its team has the knowledge and skills to implement cost-effective projects with cutting-edge, state-of-the-art technologies.

### Cleangrad: Trusted by the Biggest Pharmaceutical Companies in the World

Cleangrad is the leading provider of cleanrooms in Europe. In its proprietary development centre, the company develops new products and improves existing products in accordance with the specifications of its customers. This year the company designed, implemented, tested, and produced fire safety windows according to GMP standards. Currently Cleangrad is the only company offering this type of solution. Cleangrad's cleanrooms are designed in a way that doors, media, and furniture are fully integrated and adapted to ventilation and technology systems. All cleanrooms are produced in accordance with GMP, FDA, and ISO standards, and are suitable for use in pharmaceutical companies, hospitals, microelectronic companies, sterile production facilities, the food industry, and laboratories.

Cleangrad counts among its customers the largest pharmaceutical companies in the world, including Pfizer, GlaxoSmithKline, Mithra Pharmaceutical, DSM, Novartis, Sandoz, Octapharma, Alcon, and Zoetis.



Photo: Cleangrad

### Excellent Results with Low Costs

The Toring Turbine company develops, produces, and sells turbine aeration systems (aerators) that use water enriched with oxygen from atmospheric air. Toring Turbine aerators are used in many wastewater treatment plants in the US, Canada, Germany, and Hungary.

The company's main product is Toring Turbine TT200 Self-Aspirating aerator, which has flexible settings and parts. The product performs exceptionally well, has high energy efficiency (it uses electric energy), and low costs of operation.

Last year the company put an aerator on the market with a newly configured floating system (polyethylene float). Currently the company is developing an Ozonation System (a system for the transfer

of ozone or oxygen), which will be available at the beginning of 2018. The turbine system for the transfer of gas into water creates tiny bubbles of air, which is the reason for the high transfer of gas molecules into the surrounding water. Because this new system has been modelled on the principles of the Toring Turbine TT200, it has high efficiency in terms of the use of electric energy, and consequently lower operating costs.

The Toring Turbine company's future goal is to expand its activities in the field of wastewater management in Germany, Austria, Spain, and Japan. It also plans to find new partners in the field of fish farming in Italy, Russia, and Germany.



Photo: Toring Turbine



Photo: Toring Turbine

# MYCRON

The economy of today is marked by processes of globalisation in which CHANGE is a constant and one that can only be followed by establishing the production of inventions and innovations on a permanent and ongoing basis.

We conduct this permanent system of innovation with the help of universities, institutes and regional development institutions, and through our own research institute, founded and registered at the Slovenian Science Office under registration no 1857.

Our company invests very intensively in R&D, which is the result of our early involvement in our customers' product development.

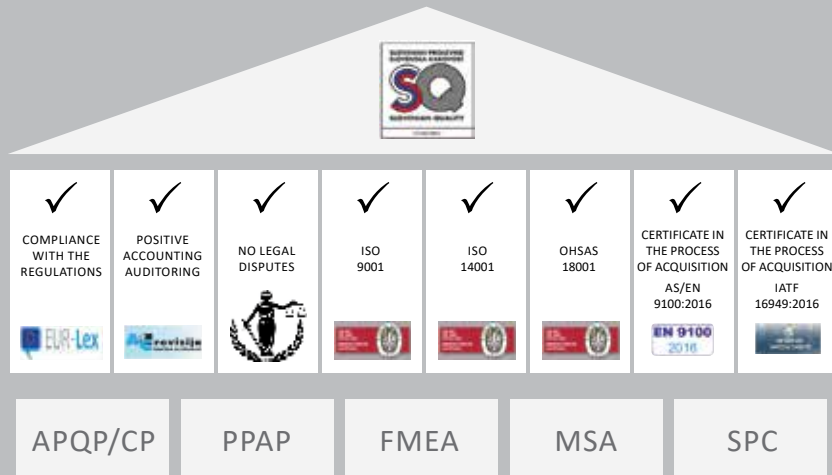

At Mycron we develop and produce strategic components that are installed into all leading brands of manufacturing machinery, medical devices, means of transport and visual communication devices around the world, from prototypes to series, from small quantities to 250,000 units per part p.a.

We provide and continuously update our machinery with the latest five-axis technology in the manufacturing of aluminium components and metal parts – up to three metres in length, including the ready-made assembly of components.

The standards achieved and the certificates obtained confirm our excellence and high quality.

Our staff are committed to meeting the DEVELOPMENT EXCELLENCE parameters at every stage. Development excellence encompasses technological, quality-related and business excellence, with a commitment to environmental and social responsibility. Our technological excellence is demonstrated by our numerous worldwide patents.

Most of our production lines already operate under the **S4 industry principles**.

The company's excellence in business has been confirmed by receipt of a **"triple A gold credit rating"**, which is based on our accounting statements and other dynamic indicators and forecasts secure and successful company operations at an above-average level in the next 12 months. It reflects our status as the most reliable, credible and low-risk company for all business partners. In fact, we are among the top **0.7% of the most reliable companies in Slovenia**.

At the company we are aware that a satisfied customer is the basis of success. We monitor the level of customer satisfaction constantly and strive to exceed our customers' expectations.



Link to video content via your smartphone.





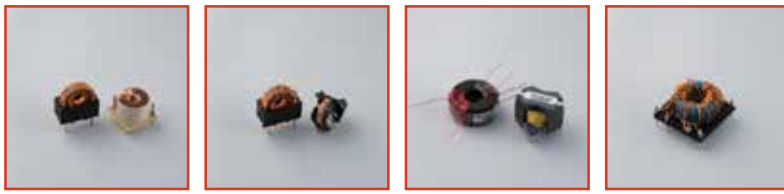

CURRENT TRANSFORMERS



RSO-CHOKES FILTERS



AIR COILS

COMPACT RECTIFIERS



ALARM SYSTEMS

EMI FILTER



RESISTORS

TOROIDAL TRANSFORMERS



TOROIDAL TRANSFORMERS



EI-TRANSFORMERS



MODIFY MOTORS



# YOUR ELECTRONIC AND ELECTRIC SHOPPING GUIDE



Company IET TOVORNIK is an independent distributor of electronic components in Slovenia. Our product range includes active and passive components.

35 years of tradition and high quality experience is our trademark.



**IET - Industrijska Elektronika Tovornik**



+386 3 746 2200



iet@siol.net



Stopče 12,  
3231 Grobelno,  
Slovenia



www.iet-sp.si/

# Companies Generating Two-Thirds of Slovene Exports

**One hundred of the fastest growing export companies in Slovenia have doubled the value of exports in the last five years.**

*Bojan Ivanc*

In 2016, the two hundred largest Slovene exporters generated revenues of 20 billion euros in foreign markets, an average of approximately 100 million euros per company. In total, these companies generated some 63% of total sales of companies in foreign markets.

**88**  
thousand people  
employed by  
the largest 200  
exporters.

In 2016, more than 1 billion euros of exports were generated by four companies. Among the top 200 exporters, 68% were in the manufacturing segment, 18% in trade, and 4% in energy and transport. The average level of exports in these companies was 83% of total revenues, more than twice as high as the average in Slovenia as a whole (39%).

**59**  
thousand euros  
value added per  
employee.

Of the top twenty Slovene export companies, half of them are foreign owned, and this share has been increasing for several years, in particular as a result of changing ownership in manufacturing companies. Within manufacturing, most exporters produce vehicles and automotive parts for the car industry. Generic medicines, household appliances, and energy also figure in the top export companies. However, due to the high growth of the automotive industry in Europe, the export dynamics of companies that supply this industry has seen accelerated growth.

Fastest-growing  
exporters employ on  
average  
**200**  
people.

Labour productivity is above average for export companies. The median of this indicator is almost 60 thousand euros, some 50% more than the aggregate average in Slovene companies.

The hundred fastest growing export companies have increased their exports from 58% up to 580% in the last five years. On average, companies doubled the value of exports during this period. The average amount of exports per company was 41 million euros in 2016. Exports accounted for an average of 80% of these companies' activities. Each employs on average 200 people, and a total of 20,000 were employed by the top export segment.

Median value added per employee in this segment was 56 thousand euros, 40% more than at other companies. Among the 20 fastest growing exporters, 11 were manufacturing companies and 6 were corporate groups. Re-export of imported vehicles from abroad greatly contributed to positive trends in international trade activity, which means that the value added generated from export was actually negligible.

# List of 200 Largest Companies by Exports in 2016

Source: non-audited and non-consolidated financial accounts of companies for the year 2016  
(publicly disclosed at Agency of the Republic of Slovenia for Public Legal Records and Related Services.)

Ranking criteria: net sales on foreign markets in 2016

Company's name	Sector	Exports (000 EUR)	% of foreign sales	Total sales (000 EUR)	Nb. of employees (avg, by hours worked)	Value added per employee (EUR)
1 GEN-I	ENERGY	1,275,713	78.0	1,635,799,28	193	90,311
2 REVOZ	MANUFACTURING	1,070,990	99.1	1,080,294,51	1,987	68,842
3 PETROL	TRADE	1,049,177	33.1	3,167,995,12	1,331	111,973
4 KRKA	MANUFACTURING	1,020,402	95.2	1,071,717,17	4,639	85,831
5 LEK	MANUFACTURING	850,158	95.0	895,270,28	3,402	94,716
6 HOLDING SLOVENSKE ELEKTRARNE	ENERGY	787,310	63.8	1,234,432,72	139	533,566
7 GORENJE	MANUFACTURING	636,461	89.3	712,450,00	4,253	32,374
8 IMPOL	MANUFACTURING	462,667	80.5	574,798,55	38	907,175
9 HELLA SATURNUS SLOVENIJA	MANUFACTURING	352,019	95.7	367,677,09	1,504	51,620
10 ADRIA MOBIL	MANUFACTURING	316,108	98.3	321,675,99	830	69,392
11 CIMOS	MANUFACTURING	312,287	98.2	318,080,13	1,596	24,875
12 INTERENERGO	ENERGY	306,905	82.8	370,551,48	25	204,909
13 SIJ ACRONI	MANUFACTURING	295,259	87.6	337,136,18	1,120	61,230
14 BSH HIŠNI APARATI	MANUFACTURING	262,832	92.0	285,608,51	1,231	43,952
15 TALUM	MANUFACTURING	241,616	79.5	303,745,91	806	46,800
16 LTH CASTINGS	MANUFACTURING	229,500	99.5	230,644,59	1,556	60,598
17 TAB	MANUFACTURING	221,794	96.5	229,925,69	604	78,169
18 SANDOZ	MANUFACTURING	214,514	100.0	214,513,81	573	45,013



RODS

TUBES

PROFILES

FOLDS

DISCS

**impol**  
Aluminium Industry

## Top Exporters

Company's name	Sector	Exports (000 EUR)	% of foreign sales	Total sales (000 EUR)	Nb. of employees (avg, by hours worked)	Value added per employee (EUR)
19 AQUAFILSLO	MANUFACTURING	208,579	99.6	209,490,40	797	44,996
20 RENAULT NISSAN SLOVENIJA	TRADE	192,996	43.8	440,314,53	107	58,398
21 MAHLE LETRIKA	MANUFACTURING	186,046	94.9	195,946,04	1,428	44,210
22 GEOPLIN	ENERGY	172,730	55.1	313,465,27	40	180,336
23 GOODYEAR DUNLOP SAVA TIRES	MANUFACTURING	171,178	82.6	207,155,87	1,326	48,168
24 SLOVENSKE ŽELEZNICE - TOVORNI PROMET	TRANSPORT	159,168	89.5	177,869,39	1,232	60,820
25 HELIOS TBLUS	MANUFACTURING	158,378	87.3	181,492,60	756	70,512
26 CARTHAGO	MANUFACTURING	152,403	100.0	152,444,09	618	29,643
27 BOXMARK LEATHER	MANUFACTURING	148,512	99.7	149,010,34	1,951	13,277
28 CINKARNA	MANUFACTURING	148,327	87.4	169,765,43	937	57,158
29 ADRIA AIRWAYS	TRANSPORT	144,185	99.2	145,350,44	368	79,814
30 KOLIČEVO KARTON	MANUFACTURING	137,498	92.4	148,733,37	375	101,457
31 UNIOR	MANUFACTURING	135,894	80.9	167,942,37	2,057	34,161
32 BELEKTRON	ENERGY	135,172	79.5	169,936,79	5	-268,615
33 LUKA KOPER	TRANSPORT	131,653	69.1	190,407,50	881	134,403
34 KOLEKTOR GROUP	MANUFACTURING	128,804	88.7	145,209,53	220	60,661
35 TELEKOM SLOVENIJE	ICT	125,003	19.5	639,470,84	2,417	114,392
36 HIDRIA ROTOMATIKA	MANUFACTURING	124,119	89.7	138,367,57	1,026	41,044
37 ODELO SLOVENIJA	MANUFACTURING	122,523	99.8	122,778,15	697	48,712
38 SIJ METAL RAVNE	MANUFACTURING	116,455	73.9	157,531,94	986	52,140
39 DOMEL	MANUFACTURING	107,994	92.5	116,736,43	858	44,625
40 DROGA KOLINSKA	MANUFACTURING	106,861	64.2	166,354,41	439	85,913
41 PRESKOK	ICT	103,777	99.7	104,128,89	6	510,927

Rollers for cold-rolling  
Cast iron rollers  
Coated rollers  
Components manufactured  
in line with client  
specifications and our  
specifications  
Special hydro-cylinders  
Metallurgical equipment  
Compound equipment  
Engineering / Planning  
Forgings / Castings  
Mechanical processing  
Thermal handling  
Quality control  
Rollers for cold-rolling  
Cast iron rollers  
Coated rollers  
Components manufactured  
in line with client  
specifications and our  
specifications  
Special hydro-cylinders  
Metallurgical equipment  
Compound equipment  
Engineering / Planning  
Forgings / Castings  
Mechanical processing  
Thermal handling  
Quality control  
Rollers for cold-rolling  
Cast iron rollers  
Coated rollers  
Components manufactured  
in line with client  
specifications and our  
specifications



## Equipment for Rolling Mills

### Metallurgical Equipment

**Forged Rollers**  
**Special Rollers**  
**Hydro-cylinders**  
**Cast Iron Rollers**

**Kolding d.o.o.**  
Nicina 12c, SI-2391 Prevalje  
T: +386 2 82 34 340, F: +386 2 82 34 350  
E: info@kolding.si  
[www.kolding.si](http://www.kolding.si)



Hydraulic Shears  
600T



Company's name	Sector	Exports (000 EUR)	% of foreign sales	Total sales (000 EUR)	Nb. of employees (avg, by hours worked)	Value added per employee (EUR)
42 VALIANT	TRADE	98,023	97.6	100,458,08	7	221,643
43 DANFOSS TRATA	MANUFACTURING	97,880	94.6	103,470,43	395	98,925
44 SAVATECH	MANUFACTURING	96,029	85.1	112,824,64	761	54,225
45 PAPIRNICA VEVČE	MANUFACTURING	92,388	95.7	96,561,44	250	52,382
46 AKRAPOVIČ	MANUFACTURING	91,355	98.9	92,366,66	826	56,464
47 ADK	MANUFACTURING	91,043	99.0	91,966,05	577	38,810
48 TRIMO	MANUFACTURING	91,017	87.7	103,740,49	350	60,313
49 KNAUF INSULATION	MANUFACTURING	85,912	78.0	110,101,50	406	82,714
50 RASTODER	TRADE	83,535	77.6	107,661,19	50	159,910
51 NUKLEARNA ELEKTRARNA KRŠKO	ENERGY	80,869	49.9	161,987,20	645	114,175
52 NOVEM CAR	MANUFACTURING	80,338	99.9	80,454,54	584	42,179
53 ADIENT	MANUFACTURING	79,316	97.9	81,038,73	581	36,274
54 PALFINGER	MANUFACTURING	78,141	95.0	82,216,74	470	45,847
55 INTERBLOCK	MANUFACTURING	78,104	96.9	80,590,73	156	247,075
56 VIPAP VIDEM	MANUFACTURING	77,653	88.3	87,989,76	337	33,350
57 VEYANCE TECHNOLOGIES EUROPE	MANUFACTURING	77,124	95.2	80,992,04	280	83,789
58 ETI	MANUFACTURING	77,066	88.4	87,154,64	761	32,823
59 BAYER	TRADE	76,988	65.2	118,083,16	118	124,094
60 SWATYCOMET	MANUFACTURING	74,333	92.2	80,601,49	825	36,273
61 KOLEKTOR ETRA	MANUFACTURING	73,632	85.1	86,532,93	337	82,382
62 PALOMA	MANUFACTURING	72,259	83.4	86,667,56	641	30,811
63 ISKRAEMECO	MANUFACTURING	71,644	95.2	75,254,45	710	34,164
64 FILC	MANUFACTURING	70,654	94.4	74,837,33	261	123,803
65 KUWAIT PETROLEUM	TRADE	70,465	88.7	79,455,39	0	-

# DOMEL

*Sustainable innovative solutions*

Domel is leading global developer and supplier of brushless and universal motors. You can find us in premium segment of household appliances, gardening, automotive and other commercial and industrial applications. Products are result of our own development and technology.

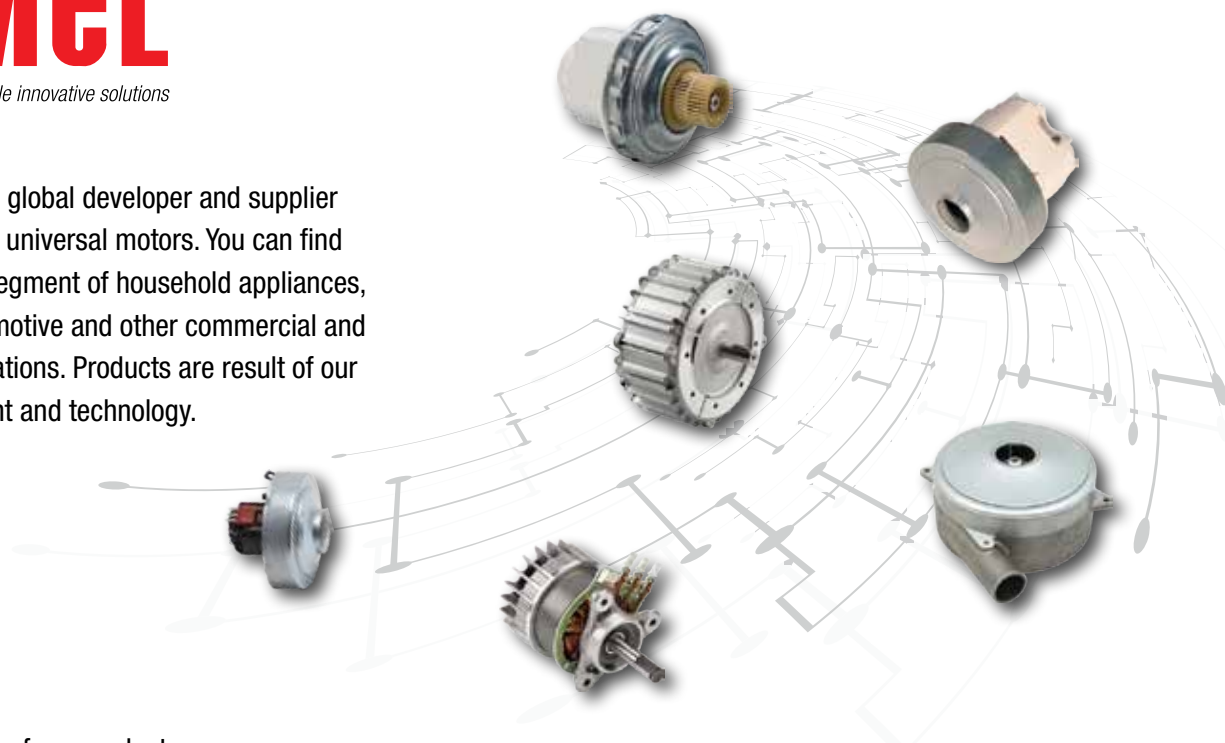

Core advantages of our products are:

**high efficiency, low noise and reliability.**

## Top Exporters

Company's name	Sector	Exports (000 EUR)	% of foreign sales	Total sales (000 EUR)	Nb. of employees (avg, by hours worked)	Value added per employee (EUR)
66 GKN DRIVELINE SLOVENIJA	MANUFACTURING	70,216	90.2	77,810,31	394	57,058
67 ARCONT	MANUFACTURING	68,666	99.1	69,283,10	676	32,334
68 EBM-PAPST SLOVENIJA	MANUFACTURING	68,154	98.1	69,500,63	404	30,387
69 TPV	MANUFACTURING	67,508	87.4	77,276,09	717	34,723
70 ELRAD	MANUFACTURING	66,114	88.4	74,793,12	428	47,608
71 ŠTORE STEEL	MANUFACTURING	65,452	69.4	94,334,81	538	40,528
72 STARKOM	MANUFACTURING	63,471	99.2	63,997,56	262	60,938
73 PERUTNINA PTUJ	MANUFACTURING	63,064	41.4	152,311,02	1,353	31,843
74 AGRINSPE	TRADE	61,328	99.0	61,978,27	4	403,746
75 GLOVIS EUROPE	TRANSPORT	61,268	91.0	67,311,62	12	530,686
76 MOBIK TELEKOMUNIKACIJE	ICT	61,017	97.3	62,737,59	25	58,286
77 TBP	MANUFACTURING	59,004	99.4	59,338,41	746	35,942
78 TITUS LAMA	MANUFACTURING	58,848	79.7	73,821,98	406	62,007
79 ISKRA MEHANIZMI	MANUFACTURING	58,128	88.0	66,041,93	381	47,199
80 GORIČANE	MANUFACTURING	57,805	87.2	66,311,97	201	65,041
81 PORSCHE INTER AUTO	TRADE	57,496	26.3	218,658,77	315	52,486
82 TOYOTA ADRIA	TRADE	56,404	56.1	100,485,10	35	88,865
83 CALCIT	MANUFACTURING	56,377	85.3	66,130,86	138	136,900
84 SILKEM	MANUFACTURING	56,191	94.0	59,772,37	187	63,922
85 ITW METALFLEX	MANUFACTURING	53,641	85.7	62,622,07	313	63,634
86 ELAN	MANUFACTURING	53,141	91.0	58,418,12	537	34,119
87 ETA CERKNO	MANUFACTURING	52,634	96.6	54,462,93	831	34,114
88 STEKLARNA HRASTNIK	MANUFACTURING	52,408	95.9	54,627,82	613	43,081
89 STORA ENSO WOOD PRODUCTS	TRADE	51,326	98.8	51,932,47	6	407,798

**lipbled**<sup>®</sup>  
The song of forest in your home!

**LIP opažne plošče Bohinj, d.o.o.**  
Ulica Tomaža Godca 5,  
SI-4264 Bohinjska Bistrica

Tel.: +386 4 5795 800  
Fax: +386 4 5795 807  
info@lipbled-bohinj.si  
www.lipbled-bohinj.si

FORMWORK  
PANELS

WITH VALUE

—  
SINCE 1948

A MEMBER of HASSLACHER group

Company's name	Sector	Exports (000 EUR)	% of foreign sales	Total sales (000 EUR)	Nb. of employees (avg, by hours worked)	Value added per employee (EUR)
90 KOVINTRADE	TRADE	50,394	42.1	119,797,12	182	45,808
91 FRUTAROM ETOL	MANUFACTURING	48,532	85.2	56,980,47	220	94,896
92 INOTHERM	MANUFACTURING	48,402	95.0	50,975,17	240	94,284
93 CABLEX-M	MANUFACTURING	47,870	96.1	49,792,46	231	45,017
94 ISKRA	MANUFACTURING	47,671	64.9	73,438,10	1,001	32,677
95 DINOS	UTILITIES	47,093	48.2	97,744,06	299	44,254
96 LEYKAM TISKARNA	MANUFACTURING	46,398	82.0	56,564,53	113	90,986
97 KOVINOPLASTIKA LOŽ	MANUFACTURING	45,800	90.8	50,442,01	609	30,229
98 TKK	MANUFACTURING	44,816	87.5	51,192,90	192	65,648
99 SAFILO	MANUFACTURING	44,602	96.4	46,274,27	938	24,362
100 BRAVOPHONE ADRIA	TRADE	44,559	100.0	44,559,17	1	340,837
101 AVTO TRIGLAV	TRADE	44,128	22.2	199,054,84	86	80,249
102 KOMPAS	TOURISM	43,906	63.9	68,744,56	204	33,407
103 STEKLARNA ROGAŠKA	MANUFACTURING	43,666	95.8	45,561,48	778	30,241
104 LJUBLJANSKE MLEKARNE	MANUFACTURING	43,546	29.4	148,220,74	530	54,572
105 LESONIT	MANUFACTURING	43,070	95.2	45,250,44	138	101,085
106 COMTRADE	ICT	43,032	91.0	47,264,36	428	82,705
107 BISOL	MANUFACTURING	42,893	98.7	43,479,25	142	34,224
108 ELES	ENERGY	42,789	27.9	153,204,65	539	137,936
109 HENKEL SLOVENIJA	MANUFACTURING	42,723	58.3	73,233,03	31	336,754
110 ASI - AVTOSERVIS SVETLIČIČ	TRADE	42,244	86.4	48,891,68	29	46,708
111 GRAMMER AUTOMOTIVE SLOVENIJA	MANUFACTURING	41,527	100.0	41,540,79	244	25,796
112 ISKRATEL	MANUFACTURING	41,165	52.4	78,526,00	544	61,809
113 FOTONA	MANUFACTURING	40,281	99.3	40,585,14	233	81,217

# Bos Grubar - with steel knowledge to success!

**One Company. Three Fields of Expertise.**

## 1. Machine manufacture

Manufacturing and construction of devices, lines and tools based on specific customer needs or requirements - We design and produce machines and tools, including waste separation and compactions machines.

## 2. Production

We provide serial manufacturing of high-quality products made of metal and plastics.

## 3. Services

Tailored to the client's needs and requirements: We provide maintenance and repair services, as well as the design and production of custom-built metal spare parts made to order.

  
z jeklenim znanjem do uspeha

## Top Exporters

Company's name	Sector	Exports (000 EUR)	% of foreign sales	Total sales (000 EUR)	Nb. of employees (avg, by hours worked)	Value added per employee (EUR)
114 ASTELLAS PHARMA	TRADE	39,653	80.6	49,216,03	39	133,581
115 KLS LJUBNO	MANUFACTURING	39,332	93.7	41,987,56	234	120,109
116 JUTEKS	MANUFACTURING	39,305	95.8	41,040,66	137	89,710
117 INTEREUROPA	TRANSPORT	39,276	43.1	91,052,16	596	42,988
118 RIKO	ENGINEERING	38,936	33.3	117,049,96	109	144,192
119 SOGEFI FILTRATION	MANUFACTURING	38,473	99.7	38,601,51	189	44,291
120 AKTON	ICT	38,448	76.5	50,249,16	25	109,760
121 MELAMIN	MANUFACTURING	37,688	86.6	43,510,07	189	70,369
122 LIVAR	MANUFACTURING	37,103	82.6	44,926,05	493	37,833
123 MK PLAST	TRADE	37,032	99.8	37,088,26	2	161,153
124 SPORTINA	TRADE	36,881	60.7	60,783,43	297	32,953
125 INCOM	MANUFACTURING	36,535	89.7	40,727,57	218	43,663
126 GOZDNO GOSPODARSTVO BLED	AGRICULTURE	36,473	84.4	43,214,08	74	71,006
127 RETIS	TRADE	36,303	90.6	40,082,41	2	95,973
128 SCANIA SLOVENIJA	TRADE	36,268	43.2	83,975,50	69	109,573
129 ODPAD	UTILITIES	36,265	66.2	54,761,33	24	101,400
130 MARIBORSKA LIVARNA MARIBOR	MANUFACTURING	35,781	93.6	38,232,78	538	24,016
131 KONTROLA ZRAČNEGA PROMETA SLOVENIJE	OTHER SERVICES	35,753	97.7	36,599,34	227	126,139
132 PLAMA-PUR	MANUFACTURING	35,681	85.7	41,653,75	204	62,687
133 MEDIS	TRADE	35,652	49.6	71,899,41	113	115,922
134 HENKEL MARIBOR	TRADE	35,515	96.8	36,703,05	499	42,569
135 SEVEN REFRACTORIES	MANUFACTURING	35,201	99.7	35,293,72	51	154,990
136 GEBERIT	MANUFACTURING	34,680	95.1	36,454,13	242	73,257



**LIVARNA  
TITAN  
KAMNIK**

Livarna Titan, d.o.o.  
Kovinarska cesta 28  
SI - 1241 Kamnik  
SLOVENIA, EU  
T: +386 (0)1 83 09 247  
F: +386 (0)1 83 09 179  
[www.livarna-titan.eu](http://www.livarna-titan.eu)



Fitingi • Fittings • Raccordi



Company's name	Sector	Exports (000 EUR)	% of foreign sales	Total sales (000 EUR)	Nb. of employees (avg, by hours worked)	Value added per employee (EUR)
137 BOSCH REXROTH	MANUFACTURING	33,940	99.4	34,144,22	232	43,072
138 CONTINENTAL ADRIA	TRADE	33,892	65.4	51,848,17	24	79,435
139 SILIKO	MANUFACTURING	33,739	72.7	46,427,50	266	58,664
140 INTERSOCKS	MANUFACTURING	33,323	93.6	35,589,06	67	67,842
141 HIDRIA AET	MANUFACTURING	32,849	96.7	33,966,77	254	58,607
142 JUB	MANUFACTURING	31,812	55.8	56,962,91	302	36,964
143 BELEKTRON EKOTRADING	TRADE	31,760	96.6	32,879,43	1	13,723
144 VIP VIRANT	MANUFACTURING	31,481	96.8	32,513,69	103	35,863
145 ADRIA KOMBI	TRANSPORT	31,421	75.1	41,839,12	13	310,273
146 PLASTIKA SKAZA	MANUFACTURING	31,332	89.1	35,167,28	188	36,981
147 ALPINA	MANUFACTURING	30,974	71.8	43,158,70	327	22,809
148 KOLPA	MANUFACTURING	30,193	71.5	42,223,63	378	33,490
149 PALFINGER MARINE	MANUFACTURING	30,186	99.8	30,257,72	90	44,384
150 KOVIS	MANUFACTURING	29,948	95.2	31,468,46	124	60,726
151 BISOL GROUP	MANUFACTURING	29,743	90.7	32,775,94	4	286,267
152 JOHNSON & JOHNSON	TRADE	29,732	73.1	40,681,53	94	125,253
153 KOLEKTOR SIKOM	MANUFACTURING	29,332	24.7	118,838,56	707	57,495
154 MEGA-METAL	MANUFACTURING	29,129	97.1	29,999,58	14	548,396
155 ATOTECH SLOVENIJA	MANUFACTURING	28,791	91.7	31,382,47	65	77,507
156 UNITIMBER	TRADE	28,787	98.7	29,151,84	3	101,871
157 FENOLIT	MANUFACTURING	28,693	82.4	34,840,97	106	68,134
158 SIBO G.	MANUFACTURING	28,424	90.6	31,364,80	203	69,197
159 ELEKTRIČNI FINANČNI TIM	TRADE	28,410	100.0	28,410,43	1	87,159
160 NIKO	MANUFACTURING	28,371	92.8	30,569,97	259	47,682

Cinkarna Celje, d.d., is the only manufacturer of white pigment in south-eastern Europe, without which modern people could not imagine their current lifestyles.

Titanium dioxide pigment ( $\text{TiO}_2$ ) is a special inorganic substance which is an indispensable integral part of varnishes and dyes, plastics materials, laminates, and paper.

Titanium dioxide enables elasticity for tyres, so that they can better adjust to road temperatures, and it prevents the deterioration of plastics materials due to light and weather conditions ...

$\text{TiO}_2$



**CINKARNA**

www.cinkarna.si

## Top Exporters

Company's name	Sector	Exports (000 EUR)	% of foreign sales	Total sales (000 EUR)	Nb. of employees (avg, by hours worked)	Value added per employee (EUR)
161 PIVOVARNA LAŠKO UNION	MANUFACTURING	28,354	19.0	149,471,08	664	83,938
162 FARMTECH	MANUFACTURING	28,206	90.9	31,032,71	253	32,533
163 YASKAWA RISTRO	MANUFACTURING	28,074	91.4	30,727,41	134	55,502
164 EXTRAFORM	MANUFACTURING	27,516	65.4	42,098,70	6	195,943
165 PREDILNICA LITIJA	MANUFACTURING	27,365	96.6	28,328,80	177	50,347
166 HYUNDAI AVTO TRADE	TRADE	27,030	46.8	57,715,96	29	95,156
167 POCLAIN HYDRAULICS	MANUFACTURING	26,888	89.1	30,178,60	271	35,838
168 MELTAL IS	MANUFACTURING	26,801	53.2	50,423,53	53	28,720
169 CABLEX-T	MANUFACTURING	26,703	84.3	31,657,40	255	34,227
170 BAUMULLER DRAVINJA	MANUFACTURING	26,638	99.2	26,864,84	187	33,676
171 ISOKON	MANUFACTURING	26,465	92.3	28,662,20	160	53,500
172 LEDINEK ENGINEERING	MANUFACTURING	26,409	98.1	26,929,60	110	51,296
173 NORTEK	TRADE	26,021	100.0	26,021,37	2	258,168
174 SUMIDA SLOVENIJA	MANUFACTURING	25,810	99.7	25,880,21	260	29,414
175 KPM MOTOR	TRADE	25,729	99.9	25,752,34	2	326,175
176 LITOSTROJ POWER	MANUFACTURING	25,627	65.3	39,262,33	391	40,859
177 MAKITA	TRADE	25,624	77.8	32,940,29	32	86,738
178 GOLD CLUB GAMING	MANUFACTURING	25,439	99.8	25,495,80	110	104,073
179 ECOLAB	MANUFACTURING	25,330	74.5	34,007,59	92	66,658
180 PPG CEE	MANUFACTURING	25,177	100.0	25,177,70	32	63,632
181 PLANIKA TURNIŠČE	MANUFACTURING	25,032	96.9	25,833,34	226	21,414
182 T.P.G. LOGISTIKA	TRANSPORT	24,925	81.9	30,422,99	48	56,446
183 MAHLE LETRIKA BOVEC	MANUFACTURING	24,758	75.7	32,713,33	288	27,401
184 MIVEKS	TRADE	24,318	98.6	24,673,27	0	-

**CNC P&K**  
 PRAZISE METALLBEARBEITUNG  
 SINCE 1976  
**CNC P&K PUŠNIK d.o.o.**  
 Mariborska cesta 56, 2360 Radlje ob Dravi  
 info@cncpusnik.si

CNC P&K d.o.o.  
 Mariborska 56, 2360 Radlje ob Dravi, Slovenia  
 Phone: +386 (0)2 88 79 670,  
 Fax: +386 (0)2 88 79 672  
 E-Mail: [info@cncpusnik.si](mailto:info@cncpusnik.si)  
 Internet: [www.cncpusnik.si](http://www.cncpusnik.si)



The mission of CNC P&K — PUŠNIK d.o.o. is metalworking, a craft we have been perfecting and developing over the past 40 years. During this time, our company has evolved into a modern medium-sized company with over 260 employees. Our company holds an important position in the Slovene economy and we are planning on expanding our activities and workforce in the near future.

Our development advantage is a combination of clear strategies, development directions and commitment to our common values: flexibility, partnership, trust, creativity, and efficiency.

CNC P&K — PUŠNIK d.o.o. follows the guidelines of sustainable development. The key principle in our operations is achieving quality at every step, which has led us to pursue and acquire international quality certificates ISO 9001, ISO 14001, and many more. This is also another testament to our company's commitment to protecting the environment, to being actively involved in our community, to improving the quality of living, and to conduct our activities with care and in a manner that disturbs the community as little as possible.

We are aware of the importance of research and its connection to practical use. All employees at CNC P&K — PUŠNIK d.o.o. are distinguished by high levels of expertise and a drive for research. Our skilled team with its many years of experience and valued references using the latest technology follows market trends and our products thus achieve world-class quality.

We are proud of our history and satisfied with the development we have achieved over the past years. Today's results serve as crucial support for our new business plans, but we are also aware of the many challenges awaiting us in the future.

The respect of our valued business partners and the trust of end users give us the obligation to keep achieving new development, manufacturing, and sales successes. We want to create this story of success together with our current and future employees.



Company's name	Sector	Exports (000 EUR)	% of foreign sales	Total sales (000 EUR)	Nb. of employees (avg, by hours worked)	Value added per employee (EUR)
185 EPS TRGOVANJE	ENERGY	24,103	100.0	24,103,00	0	-
186 BELIMED	MANUFACTURING	23,887	95.7	24,953,24	202	40,343
187 ADRIA DOM	MANUFACTURING	23,688	95.8	24,732,37	208	40,001
188 IMERYS FUSED MINERALS	MANUFACTURING	23,535	97.4	24,164,64	70	110,604
189 ADLES	MANUFACTURING	23,169	94.1	24,615,78	10	415,906
190 GMT	TRADE	23,137	43.1	53,736,44	102	58,385
191 SOFIMEX	TRADE	22,988	89.6	25,648,02	4	91,197
192 HC HIDROMONTAŽA	CONSTRUCTION	22,559	100.0	22,558,59	21	169,297
193 LUKEM	TRADE	22,250	98.3	22,643,20	9	117,931
194 MS KLJUČAROVCI	TRADE	21,618	70.3	30,768,39	17	43,310
195 FLUIDMASTER	MANUFACTURING	21,521	91.2	23,596,29	188	34,606
196 REM	MANUFACTURING	21,472	59.8	35,906,43	146	67,924
197 ŽITO	MANUFACTURING	21,229	20.8	102,170,76	834	33,352
198 URSA SLOVENIJA	MANUFACTURING	21,056	85.8	24,534,36	116	56,757
199 FMS LOGISTIKA	TRANSPORT	20,981	88.4	23,723,53	15	53,769
200 STUDIO MODERNA	TRADE	20,640	54.4	37,915,03	352	58,251

Source: Ajpes, public data

# »MAKOP«

[www.makop.si](http://www.makop.si)

With our help, you get the plastic product tailored to suit you.



#### Injection molding of plastic

- For the automotive industry
- For the electrical appliance industry
- For the household appliance industry
- Manufacture of injection molds
- Project management

We offer you an end-to-end solution. You send us the drawing and we take all necessary steps that your product can be mass-produced.

#### We offer you:

- o Thermoplastic injection molds
- o Assembly or completion of components
- o Manufacture of injection molds

#### We are specialized in injection molding of:

- Sophisticated measuring products
- Products with inserts (metal, sensors)
- Aesthetically appealing products

We as well can install injection molded products during the process or complete them into individual components.

We mostly use the following materials: PA, PBT, SAN, POM, PP, TPE, PC, ABS, PMMA. Our manufacturing process makes the traceability of products possible and guarantees the high quality of injection molded products. Measuring of the products takes place in our own measuring laboratory. Our tool manufacture developed through the manufacturing of tools for our own use and for external customers.

#### Company

- o We process plastics since 1984
- o 4000 m<sup>2</sup> production area at two locations  
Domžale branch, Kozje branch
- o Modern machine park; 26 injection molding machines with clamping forces of 50t to 550t
- o In-house tool manufacture
- o Fireproof tool storage
- o Injection molding of more than 500 different products
- o ISO 9001:2008

Our yearlong tradition and rich experience and expertise make us a reliable partner for our customers who at all times can expect rapid response, flexibility and high-quality service from us.

# The right partner for electromechanical solutions

**Eurel is the right company for provision of electromechanical products and services, integrated mechatronic solutions - from concept design to mass production.**

Slovene company Eurel is a supplier of innovative systems for large enterprises in the field of electromechanics. They provide their customers with comprehensive services, i.e. from idea to final product.

## Competitive and innovative

The company's primary business is the development and production of electro-mechanical components, assemblies and devices. They are distinguished by high quality, reliability, flexibility, innovation and competitive prices. Investment in new products is a constant process in their company and it will remain so in the future. Since

they collaborate with domestic and foreign research institutions, their products are the result of the latest skills and knowledge in the field of materials and technologies. The products and manufacturing technologies of Eurel are all environmentally friendly.

## Collaboration already in the pre-development phase

Often, their collaboration with the client starts in the pre-development phase, i.e. making development concepts, and continues in all subsequent stages of development. Their development tools are PTC Creo 3.0 and Siemens NX 8.5. They continuously use computer simulation using finite element method analysis, development and laboratory measurement based on National Instruments LabVIEW. Furthermore, they

develop most of the instrumentation and control equipment for data acquisition and their subsequent statistical analysis.

In its strive to effectively accommodate market demands and take better control of business processes, Eurel has implemented and maintained quality management system that meets requirements of the standard IATF 16949, as they are active supplier in the automotive industry.



PROMO



The Lightness of the Future 



PRIMARY ALUMINIUM

SLUGS

BILLETS



WIDE STRIPS

ALLOYS

EVAPORATORS

CASTINGS

# List of 100 Fastest Growing Companies by Exports in the Period 2012-2016

Source: non-audited and non-consolidated financial accounts of companies for the year 2016 (publicly disclosed at Agency of the Republic of Slovenia for Public Legal Records and Related Services.)

Ranking criteria: growth in exports in the period 2012-2016 for companies with exports above 5 million euros threshold in 2012.

Company's name	Sector	% change in exports (2016/2012)	Exports (000 EUR)	% of foreign sales	Nb. of employees (avg, by hours worked)	Value added per employee (EUR)
1 RENAULT NISSAN SLOVENIJA	TRADE	578.1%	192,996	43.8	107	58,398
2 SCANIA SLOVENIJA	TRADE	388.0%	36,268	43.2	69	109,573
3 ASTELLAS PHARMA	TRADE	313.0%	39,653	80.6	39	133,581
4 MS KLJUČAROVCI	TRADE	278.7%	21,618	70.3	17	43,310
5 SEVEN REFRACTORIES	MANUFACTURING	277.6%	35,201	99.7	51	154,990
6 GOZDNO GOSPODARSTVO BLED	AGRICULTURE	253.7%	36,473	84.4	74	71,006
7 VIP VIRANT	MANUFACTURING	230.7%	31,481	96.8	103	35,863
8 REM	MANUFACTURING	183.6%	21,472	59.8	146	67,924
9 ALIUS	MANUFACTURING	182.4%	16,230	98.3	118	47,622
10 VIPOLL	MANUFACTURING	180.8%	16,632	90.4	114	49,756
11 PRIMAT	MANUFACTURING	171.5%	19,549	94.7	226	32,938
12 INTERBLOCK	MANUFACTURING	169.8%	78,104	96.9	156	247,075
13 DEWESOFT	ICT	164.6%	14,683	95.4	56	128,988
14 MAROVT	MANUFACTURING	161.7%	16,730	94.8	208	40,936
15 SOLCHEM	TRADE	156.4%	13,469	47.7	30	79,993



## Advantages of concrete PREFABRICATED BATHROOMS

- Mechanical resistance to external influences
- Fire resistance
- Sound insulation
- Sustainability
- Waterproof - Resistance

## WE DESIGN AND PRODUCE

TO SUIT YOUR REQUIREMENTS

- prefabricated bathrooms
- skateparks
- pump tracks
- design radiators



Visit us at  
[www.varis-group.com](http://www.varis-group.com)

## Top Exporters

Company's name	Sector	% change in exports (2016/2012)	Exports (000 EUR)	% of foreign sales	Nb, of employees (avg, by hours worked)	Value added per employee (EUR)
16 AREX	MANUFACTURING	150.7%	13,941	85.8	91	80,550
17 TITUS LAMA	MANUFACTURING	147.6%	58,848	79.7	406	62,007
18 BAUMULLER DRAVINJA	MANUFACTURING	140.9%	26,638	99.2	187	33,676
19 SOŠKO GOZDNO GOSPODARSTVO	AGRICULTURE	139.9%	12,749	83.7	127	29,698
20 PORSCHE INTER AUTO	TRADE	138.8%	57,496	26.3	315	52,486
21 CABLEX-M	MANUFACTURING	138.2%	47,870	96.1	231	45,017
22 VALIANT	TRADE	136.5%	98,023	97.6	7	221,643
23 BELIMED	MANUFACTURING	136.2%	23,887	95.7	202	40,343
24 INCOM	MANUFACTURING	134.6%	36,535	89.7	218	43,663
25 ELES	ENERGY	131.7%	42,789	27.9	539	137,936
26 COSYLAB	ICT	128.8%	12,019	89.4	83	145,960
27 POČKAJ	MANUFACTURING	128.8%	16,991	99.5	80	56,410
28 GRAFO LIT	TRADE	128.0%	13,057	52.8	22	52,439
29 FOTONA	MANUFACTURING	126.0%	40,281	99.3	233	81,217
30 HOČEVAR	MANUFACTURING	125.6%	17,718	91.6	17	98,161
31 LEDINEK ENGINEERING	MANUFACTURING	125.0%	26,409	98.1	110	51,296
32 RLS	MANUFACTURING	121.5%	13,754	94.1	108	77,113
33 CELJSKE MESNINE	MANUFACTURING	117.4%	11,243	14.6	333	25,588
34 HYUNDAI AVTO TRADE	TRADE	116.1%	27,030	46.8	29	95,156
35 DZS GRAFIK	TRADE	112.8%	16,252	57.0	37	63,059
36 SOGEFI FILTRATION	MANUFACTURING	111.6%	38,473	99.7	189	44,291
37 PIVOVARNA LAŠKO UNION	MANUFACTURING	111.3%	28,354	19.0	664	83,938
38 OMEGA AIR INŽENIRING	MANUFACTURING	109.2%	11,722	68.2	159	45,216
39 ELRAD	MANUFACTURING	108.6%	66,114	88.4	428	47,608

# MALI-E-TIKO d.o.o.

## Professional Metal Products Since 1988

MALI-E-TIKO provides a wide range of products and services in the manufacture of elements and components from sheet metal for the needs of the electronics and automotive sectors, including parts for heavy machinery and equipment, which requires expert knowledge of metal processing and machining.

Holding ISO 9001-2008 certification, the Tržič-based MALI-E-TIKO manufactures components for, amongst others, the electronics and car industries, as well as elements for commercial vehicles and construction equipment.

### Electronics

In addition to a range of component elements for the automotive industry, the company makes casings and housings for electronics, a variety of custom-made aluminium and alloy heat sinks, together with cases for electronic equipment and amplifiers.

MALI-E-TIKO engineers elements of the most complex design, manufactured using multi-axis CNC milling machines.

### Heavy-duty Equipment

MALI-E-TIKO manufactures elements and parts for road vehicles and construction equipment, heavy-duty machines, components for professional ironing systems and heating solutions, inox steel road and other signs, as well as a range of metal cabinets and storage systems.

MALI-E-TIKO's metal processing services include milling and turning, as well as the welding of all types of materials (TIG, MIG and MAG welding). The company employs certified European welding engineers and holds EN ISO 3834-2 and EN 1090-2 certificates. In addition to sandblasting, MALI-E-TIKO's contractors also provide surface protection (galvanised coating), anodising, chromate coating, as well as powder and wet coating. Additional services encompass engraving, including laser engraving, and screen printing.

### Product Development

The company collaborates with its clients in product development, employing 3D technology (PTC Creo, AutoCAD) for design, as well



as the latest software for CNC programming. Among other services, MALI-E-TIKO provides laser cutting of steel, stainless steel and aluminium, as well as CNC punching and bending of materials using modern CNC machinery (Trumpf, Gasparini and LVD).

### Partners in Germany, Austria and Italy

MALI-E-TIKO products supply its partners in Germany, Austria and Italy. Germany is the company's main market, where clients include ANNAX GmbH, BOMAG GmbH and Veit GmbH; in Austria - Swarco Futurit GmbH and Palfinger AG; and CAEN S.p.A. in Italy. Through a number of its Slovenian partners MALI-E-TIKO manufactures can be found in many parts of the world, including the Middle and Far East, South America, the UK, Hong Kong and Japan.

The companies MALI-E-TIKO works with are leaders in their respective fields. Moreover, their partners include them in current and future projects, thereby transferring know-how and engineering expertise.

Company's name	Sector	% change in exports (2016/2012)	Exports (000 EUR)	% of foreign sales	Nb, of employees (avg, by hours worked)	Value added per employee (EUR)
40 REFLEX	CONSTRUCTION	108.2%	13,947	46.9	344	24,812
41 MDM	MANUFACTURING	107.5%	13,487	35.3	83	67,071
42 ISKRA ISD - LIVARNA	MANUFACTURING	106.1%	10,841	88.2	142	35,902
43 MEGALES	TRADE	102.1%	17,581	90.8	44	63,460
44 GOZDNO GOSPODARSTVO NOVO MESTO	AGRICULTURE	100.1%	10,654	47.0	177	32,365
45 TECHNOPLAST	MANUFACTURING	99.0%	14,485	95.6	170	15,976
46 STARKOM	MANUFACTURING	98.3%	63,471	99.2	262	60,938
47 INTERENERGO	ENERGY	98.2%	306,905	82.8	25	204,909
48 STAMPAL SB	MANUFACTURING	97.8%	10,175	85.3	46	78,467
49 ADRIA DOM	MANUFACTURING	96.5%	23,688	95.8	208	40,001
50 ATOTECH SLOVENIJA	MANUFACTURING	95.5%	28,791	91.7	65	77,507
51 VITIVA	MANUFACTURING	95.5%	11,359	95.9	67	61,860
52 TPV	MANUFACTURING	93.9%	67,508	87.4	717	34,723
53 INDUSTRIJA TRANSPORTNIH SREDSTEV IN OPREME	MANUFACTURING	93.8%	13,174	97.4	103	33,777
54 AKRAPOVIČ	MANUFACTURING	93.5%	91,355	98.9	826	56,464
55 CLEANGRAD	MANUFACTURING	92.3%	9,666	97.3	92	37,953
56 KLS LJUBNO	MANUFACTURING	91.8%	39,332	93.7	234	120,109
57 PRESKOK	ICT	91.4%	103,777	99.7	6	510,927
58 DSV TRANSPORT	TRANSPORT	90.0%	18,955	49.1	140	46,187
59 MERCIS	TRADE	89.8%	10,294	80.6	34	65,441
60 STILLES	MANUFACTURING	86.1%	15,047	95.6	199	28,955
61 CABLEX-T	MANUFACTURING	84.8%	26,703	84.3	255	34,227
62 KOLEKTOR	MANUFACTURING	84.4%	16,446	63.5	237	24,554



[www.tehnos.si](http://www.tehnos.si)



- ◆ The production of own products and semiproducts for household appliances, automotive and aviation industry.



## Top Exporters

Company's name	Sector	% change in exports (2016/2012)	Exports (000 EUR)	% of foreign sales	Nb, of employees (avg, by hours worked)	Value added per employee (EUR)
63 GEOPLIN	ENERGY	83.4%	172,730	55.1	40	180,336
64 LTH CASTINGS	MANUFACTURING	82.8%	229,500	99.5	1,556	60,598
65 HYLA	MANUFACTURING	81.9%	15,084	94.7	42	87,594
66 PETEK TRANSPORT	TRANSPORT	80.6%	11,509	72.6	128	36,730
67 MERCURY PROCESSING SERVICES INTERNATIONAL	ICT	80.3%	9,065	62.6	83	57,979
68 CNC P&K-PUŠNIK	MANUFACTURING	80.1%	18,592	96.0	249	40,260
69 I,H,S,	MANUFACTURING	78.4%	14,847	97.3	97	55,088
70 ADRIA AIRWAYS TEHNIKA	MANUFACTURING	76.7%	15,575	65.8	213	55,156
71 MOBIK TELEKOMUNIKACIJE	ICT	76.5%	61,017	97.3	25	58,286
72 WILLY STADLER	MANUFACTURING	76.4%	14,544	88.0	100	71,654
73 BELEKTRON	ENERGY	75.8%	135,172	79.5	5	-268,615
74 CALCIT	MANUFACTURING	75.1%	56,377	85.3	138	136,900
75 S E P	MANUFACTURING	74.2%	11,932	87.1	141	33,160
76 PIPISTREL	MANUFACTURING	74.1%	14,123	96.4	107	61,271
77 PLASTIKA SKAZA	MANUFACTURING	72.5%	31,332	89.1	188	36,981
78 ŽITO	MANUFACTURING	72.3%	21,229	20.8	834	33,352
79 SILIKO	MANUFACTURING	71.5%	33,739	72.7	266	58,664
80 VIVAPEN	MANUFACTURING	71.3%	8,834	98.1	94	38,659
81 NOVEM CAR	MANUFACTURING	71.0%	80,338	99.9	584	42,179
82 SANDOZ	MANUFACTURING	70.9%	214,514	100.0	573	45,013
83 VARIS	CONSTRUCTION	69.9%	18,762	99.3	214	29,884
84 GMT	TRADE	69.9%	23,137	43.1	102	58,385
85 POLYCOM	MANUFACTURING	68.8%	18,387	73.4	190	46,667
86 GEFCO	TRANSPORT	67.8%	13,607	73.8	21	66,246
87 KOLEKTOR ETRA	MANUFACTURING	67.8%	73,632	85.1	337	82,382
88 PLASTA	MANUFACTURING	67.0%	13,490	59.4	120	65,378
89 MEDIS	TRADE	66.7%	35,652	49.6	113	115,922
90 EHO	MANUFACTURING	66.4%	11,432	77.0	77	55,491
91 TAB	MANUFACTURING	64.7%	221,794	96.5	604	78,169
92 DOMEL	MANUFACTURING	63.8%	107,994	92.5	858	44,625
93 ŠKRLJ KOVINSKA OPREMA	MANUFACTURING	62.9%	15,619	94.7	83	70,818
94 FARMTECH	MANUFACTURING	61.6%	28,206	90.9	253	32,533
95 HC HIDROMONTAŽA	CONSTRUCTION	60.8%	22,559	100.0	21	169,297
96 YASKAWA RISTRO	MANUFACTURING	60.4%	28,074	91.4	134	55,502
97 EM PK	MANUFACTURING	60.3%	9,285	96.6	27	19,733
98 ORODJARNA & INŽENIRING ALBA	MANUFACTURING	59.5%	9,129	96.8	93	43,058
99 SAXONIA - FRANKE	MANUFACTURING	59.4%	11,479	98.9	65	76,857
100 PFEIFER & LANGEN	TRADE	58.1%	12,850	56.7	25	77,289

Source: Ajpes, public data





**DONIT TESNIT, d.o.o.**  
 Cesta komandanta Staneta 38, 1215 Medvode, Slovenia  
 Phone: +386 (0)1 582 33 00 Fax: +386 (0)1 582 32 06  
 E-mail: info@donit.eu www.donit.eu

# Engine of innovation and change

**In order to enable its members to expand, the ABC Accelerator is also expanding and creating a network of knowledge, contacts, mentors and business angels, with access to risk capital.**

Less than three years ago, a simple accelerator was created in Slovenia, a country with a perfect geographical location and links to the rest of the world. Its vision was to bring the world closer to young innovative enterprises (startups) and help them to conquer it more quickly. The idea behind the ABC Accelerator was that the world was very small and that the recipe for conquering it was one that was constantly changing. We also wanted Slovenia to become a meeting point for new digital solutions in a variety of fields – and not just regionally but globally too. We are therefore building on the success stories that have come to Slovenia via the ABC and making connections with Slovenian or foreign companies – which we then send out, through our network, to conquer the world.



Through this we are realising the idea of linking and creating ecosystems – which we believe are key to newly established companies.

## Network in Europe and the US

Up to now, the ABC Accelerator has promoted over 80 startups and collected over EUR 30 million of investment. In order to achieve this in such a short space of time, we have also had to expand throughout the world ourselves. Today we have branches in the US (San Jose in Silicon Valley), Munich, Kiev and Tuzla, and we are connected to many ecosystems on which



we can always rely when we need the right connections for our own startups.

Because of its excellent network and its location at WeWork, ABC Accelerator Silicon Valley is able to offer startups immediate contact with the right risk capital representatives, business angels, mentors with several highly successful startups behind them, including Uber and AirBnB, and sponsors who have, along the way, helped giants such as Tesla and Apple.

In Germany, startups come into direct contact, via ABC Accelerator Germany, with large tech companies interested in using their solutions – or, of course, in investing in them. At both locations, we arrange offices for startups and provide staff with accommodation in our startup apartments. ABC ensures that young entrepreneurs are focused solely on their business and provides them with everything they need to grow quickly.

## Large enterprises teach innovation

Today, ABC is a global company that brings together different ecosystems and has a direct insight into the creation of the innovations and technologies that will shape our future. For this reason we created, a year ago, a special programme, the ABC Enterprise Accelerator, where we

teach traditional large companies innovative approaches to business, and ways of installing visions aligned with the history of the company and the signals of the future. We connect them with various world-famous names that already have a wide and varied portfolio of global companies to whom they have demonstrated new methods of innovation and management.

## Gurus of innovation and talents of tech

A number of world-renowned figures have appeared as part of our programme, including Patrick Cowden ('Beyond Leadership'), Herman Gyr, Lisa Friedmann and Laszlo Gyorffy from the Enterprise Development Group of Palo Alto, and Andy Baynes from Nest Labs. As our programme is modular, companies can join anywhere. Because of the exceptional tech talents we have at our disposal in the network via the ABC Move On Miles programme, we are able to provide enterprises and startups with new tech associates at any time, or create programmer project teams to work on specific projects only.

After almost three years, we can say that the ABC Accelerator has truly become an 'engine of innovation and change' – for startups as well as larger companies, in the Slovenian and global senses of the word.

YOUR DEVELOPMENT FOUNDRY  
FOR MORE THAN 60 YEARS.



## DUCTILE & GREY IRON CASTINGS

Excellence, innovation, and responsibility are the key drivers in every part of our business.

We come from a background of strong tradition and experience, while simultaneously striving to base our future on new knowledge. But above all, our main goal is to continuously build partnerships even stronger than the iron we cast.

**Livar d.d.**  
info@livar.si  
+386 1 786 99 00  
[www.livar.si](http://www.livar.si)



# Slovenian National Innovation Awards 2017



## »The Future Belongs to Those Who Believe in Dreams.«

**Slovene surpluses in 2017: 12 golden awards, 25 silver awards, one honourable mention for a young company and the best innovation chosen by the public.**

*Polona Movrin*

**The CCIS Best Innovation Awards: the recognition of innovation with the longest tradition in Slovenia.**

The Chamber of Commerce and Industry of Slovenia celebrated the 21st National Awards for the best innovations in Slovenia. Boštjan Gorjup, CCIS President, articulated a vision that will improve the standard of living for the active population by the year 2025, as well as for youth under the age of 25 and people over 55.

»In order to realize our visions, we need innovative and talented people,« Gorjup said, adding: »The future belongs to those who believe in dreams.«

### **To Make Dreams Come True With Our Collective Power**

The experience of gold award winners confirms that for dreams to come true, whether they are about innovations or something else, hard work, courage, and a good team are needed.

»We had some ideas but when we looked at them closely, we discovered they would be very difficult to achieve. We almost abandoned the idea of making foldable skis that could actually be skied on, but then

we passed through the crisis and made the idea a reality,« said Vinko Avguštin of Elan.

### **Let's Think, Dream, Do**

Some of the outstanding innovators told us about their way to success. Ana Roš explained how she achieved the title of the best cook in the world. The first big test was when she gathered the courage to tell her parents that she would take over her parents-in-law's restaurant with her husband. »The second big test was when I found myself in the kitchen with knowledge of diplomacy, five languages, history, and economics, but not very much knowledge of cooking.« Success came after fourteen years of hard work.

Peter Slatnar, who took over the production of ski jumps from Elan, believes that dreams are a good basis for innovation. »I had such a vivid dream one night that I got out of bed, got dressed, and went to the workshop. When I got there, I wondered where all the workers were, and then I looked at the clock and realized it was midnight.«

## GOLDEN AWARDS

Aereform

### Flight Simulator Using VR Goggles for Basic Training of Pilots

The flight simulator employing VR goggles essentially differs from all other simulators in that it effectively enables the pilot a shift of view across the entire visual field. The VR goggles also adjust the focal point according to the position of the user's head, thus the image adjusts with it. It is equally important that this simulator is extraordinary immersive, and during a session it ingeniously and convincingly takes the user into a different space and time. Another vital advantage of this simulator is that it can be used in basic aircraft piloting instruction and training, which the majority of existing simulators do not facilitate.

This innovation confirms Aereform's business and development model of manufacturing complex high-value-added products. These derive from a wide range of in-house technological solutions developed by its personnel. Aereform has consolidated its position as a development partner of Pipistrel Aircraft, and won great renown as a highly proficient and innovative prototype constructor. A small, high-quality company in the field of light aviation technology, Aereform's vision is to become the partner of choice in prototype vehicle development.

Innovators: Sašo Knez, Nika Mlinarič, Aljoša Skočir, Ines Repnik, Aljaž Trebušak, Nino Razpotnik, David Hanč



Photo: Aereform



Photo: BSH Hišni aparat

BSH Hišni aparati Nazarje

### OptiMUM

The OptiMUM is an universal kitchen appliance, and the innovation lies in the design of its individual elements, such as housing, gearbox and the shape of attachments used for optimal food processing. Based on intelligent technology, the OptiMUM has a powerful 1500 W motor and an extra-large 5.5 litre capacity brushed stainless steel bowl, while its integrated scales - a unique feature on the market - save time and make the preparation of complex recipes easy. Thanks to its intelligent SensorControl Plus automated programmes, dough, cream and egg white of perfect consistency can be prepared automatically. A vast array of accessories ensure the simple realisation of a huge variety of cooking and baking ideas, including the preparation of home-made pasta, juicy burgers and healthy smoothies. The OptiMUM has received the IF Design Award 2017, as well as the Red Dot Award 2017 for design excellence.

Innovators: Matej Čater, Uroš Semeja, Aleš Brečko, Peter Kovačič, Boštjan Kovačec, Tadej Holcinger, Gregor Slakan, Igor Dečman, Aleksander Strojanišek, Matej Švara, Tomaž Robida, Simon Knez, Roman Pačnik, PhD., Henri Orbanič, PhD., Jože Lesjak, Aleš Jakše, Marko Lenošek, Blaž Slatinšek, Marko Ivanušič

CETIS

### E-Passport Data Page Polycarbonate Binding Solution

Cetis has developed a new generation of bound polycarbonate data pages for use in biometric passports. The patented solution includes numerous improvements in terms of safety, durability, flexibility, compatibility and reliability. In addition to the more than 50 extant safety features, the innovation carries additional watermark and ultra violet protection systems, further enhancing Cetis as a world leader in the provision of polycarbonate data pages for passports.

Innovators: Roman Žnidarič, MSc, Jana Hleb, Franci Zajc, Milan Kerič



Photo: Cetis



Photo: Danfoss Trata

Danfoss Trata

**NovoCon – Smart Hydronic Actuator for HVAC Systems**

The NovoCon smart hydronic drive actuator for HVAC systems provides a solution that can deliver large savings in poorly dimensioned or implemented heating and cooling systems in which energy consumption is up to 50% more than is necessary. NovoCon's advantage lies in its greater precision and flexibility in covering different HVAC applications, in its allowing quick incorporation of additional sensors, new alarm functions, as well as in the possible integration of certain HVAC regulator functions. All these reduce investment in infrastructure as well as deliver greater energy savings.

Innovators: Lars Munch, Igor Azinovič, Andraž Konarček, Primož Gorjup, John Kelly, Sean Boden

Elan

**Foldable Touring Skis Elan Ibex Tactix & Foldable Touring Skis for Special Forces**

When carried on a backpack, long classic touring skis make walking difficult, especially when traversing dwarf pine plantations or attempting to climb through difficult terrain. In order to improve the mobility and safety of extreme tour skiers and alpine military units, ski maker Elan has developed functional foldable back-country skis for the Slovene army. Known as the Elan Ibex Tactix, these skis allow easier transport and greater agility, and are a novelty on the global market. These foldable skis, which will be available for civilian use from 2018 onwards, provide users with a supreme quality skiing experience, enabling everything from descent from a helicopter to easy navigation through demanding terrain.

Innovators: Vinko Avguštin, Andrej Hrovat



Photo: Elan



Photo: ETI

ETI Izlake

RC eNeM Novi Materiali

**Technological Developments in the Manufacture and Processing of Thermostatic Elements**

The integration of innovative high technology manufacturing has resulted in major improvements in the high-capacity manufacture of thermostats. This has provided ETI with a huge advantage over its competition that will enable the company to become a leading manufacturer of thermostat elements.

Innovators: Gregor Ceglar, Jure Raspotnik, Damjan Strmljan, Samo Urbanija, Maja Macerl, Franci Ocepek, Ines Bantan, Simon Lebar, Joži Prašnikar, Peter Bregar

Gorenje

**New Generation of Dishwashers SmartFlex**

The new generation of SmartFlex dishwashers excel in their extremely low energy consumption (10% below the A+++ grade energy efficiency threshold). The SmartFlex DW30's impressive stainless steel interior, one of the largest on the market, can accommodate 16 place settings at a time, and even 35 cm diameter plates. Equipped with a special water tank, that reduces water consumption to only 6.9 litres per cycle, the DW30 is also super silent, operating at a mere 41 dB.

Acclaimed in independent professional magazines and guaranteeing perfect washing results, the new SmartFlex range also excels in relation to the unique automatic door opening and optical signal display (both patent pending), low consumption water tank replete with special filter systems, and special effect exterior LED light.

Such innovations further strengthen Gorenje's position in demanding global markets. Innovators: Mats Lilja, Anders Sahlen, Thomas Persson, Aleš Osredkar, Jernej Heindl, Jana Kovač, Ksenija Sovič, Alen Kešetović, Peter Sevčnikar, Stanko Kanduti, Damjan Novak, Borut Keržič, Dejan Kokol



Photo: Gorenje

Photo: Iskraemeco



Iskraemeco

### Smart Electricity Meter Platform

With an innovative platform approach, this next generation smart meter enables the seamless integration of smart metering functions in the context of the smart grid. The platform complies with EU functional requirements for smart meters and facilitates easy and cost-effective adaptation to various national market requirements. It also provides a solution to the key challenges faced by electricity distributors who want to transition to the smart grid.

Innovators: Tomaž Dostal, Miha Ušeničnik, Vjekoslav Delimar, Janez Zavašnik, Petar Štimac, Tibor Rafa, Uroš Jerman, Luka Šparovec, Gregor Rodič, Uroš Bizjak, Tomaž Peterman, Jure Arh, Ludvik Kumin, Tomaž Brejc, Klemen Omahen, Boštjan Dolžan, Simon Boštar, Simon Balanč, Primož Košir

KRKA Novo mesto

### Process Optimisation of Active Pharmaceutical Ingredient Candesartan Cilexetil Production

Krka has developed a new process for manufacturing the prodrug Candesartan Cilexetil, which it has now introduced into industrial scale production. The innovative procedure is accomplished using primary input ingredients, namely, substances which are cheaper and easier to obtain than those used in the erstwhile process.

This new procedure is some 30% more efficient, and Krka has replaced the ecologically problematic tributyltin compounds with ecologically more acceptable ones. The introduction of regenerated solvents in this process also confirms that environmental protection remains an important factor in Krka's business strategy.

Innovators: Jerneja Böhm, Miro Dobravc, David Kralj, PhD, Dušan Krašovec, Tadej Stropnik, Silvo Zupančič, PhD

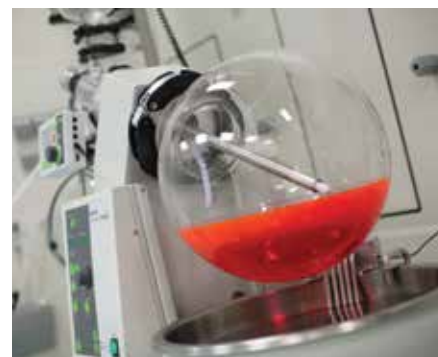

Photo: Krka

Photo: Ledinek Engineering



Ledinek Engineering

### System of Active Floatational Planing with Continuous Symetrical Distribution of Left and Right Decrease

Using innovative floating vertical spindle technology, which actively assists integrated motor-drive machining, Ledinek Engineering has delimited one of the most exacting processes of high performance industrial planing. State of the art software calculates and compensates vertical movement and curves in the board in real-time. The highly responsive data-driven process also ensures constant centring and gauging of the thickness of the board, thus the actual feed speed through the planer is optimised.

Through the application of computer technology, the Stratoplan 4VA planer avoids any jamming or breaking of the workpiece, and ensures cut-offs are kept to a minimum. Most significantly, the Stratoplan 4VA has some three times the capacity of a conventional machine planer.

Innovators: Viljem Ladinek, Stanislav Vidovič, Janez Klemenčič (Simat - Janez Klemenčič)

Lek farmacevska družba, Razvojni center Slovenija

**Novel Children Friendly Form of Antibiotic**

The treatment of bacterial infections in children is challenging. Swallowing large tablets can be difficult, while liquid suspensions have their shortcomings – they need to be kept in a fridge and accurate dosing is not easy. Lek has thus been endeavouring to develop a more suitable pharmaceutical form.

With a thirty-year tradition in producing one of the most popular medicaments in the treatment of bacterial infection, Lek's development of this more child-suitable form of drug delivery began in 2012. Taking an innovative approach, Lek's development of a fast dissolving tablet containing Amoxicillin and Clavulanic acid has today succeeded in doing away with all the shortcomings of liquid suspensions. The new tablet is simple to administer, allows precise dosing, has a better taste and is easier to store as it does not need to be refrigerated.

Innovators: Rok Starič, Petra Perhavec, Dejan Krajcar, Marko Oblak, PhD, Mateja Šikovec, PhD, Urška Korošec, Lidija Pušnik Verdnik



Photo: Lek



Photo: SIJ Acroni

SIJ Acroni

Razvojni center Jesenice

**Fly with SINOXX 4542 Steel**

With this award-winning innovation, SIJ Acroni has established the foundations for incorporating a new group of stainless steels into the company's production programme. Together with austenite, ferrite and martensite stainless steels, SIJ Acroni is henceforth able to manufacture precipitation hardened steels intended for technological applications in the most demanding environments.

Large dimension SINOXX 4542 plates can also be provided final heat treatment, significantly reducing the time and production costs, thus SIJ Acroni's customers also benefit from the added value of this intermediate product.

SIJ Acroni is further fortifying its position as a niche manufacturer of supreme quality steel and has positioned itself as a market leader in the provision of specialist steels for the paper and chemical industries, as well as manufacturers of specialist machine parts for the aircraft industry.

Innovators: Boštjan Bradaškja, PhD, Boštjan Pirnar, MSc, Matevž Fazarinc, PhD, Grega Klančnik, PhD, Stanislav Jakelj, Viktorija Marušič, MSc, Milan Klinar, MSc, Robert Robič, Anton Košir, MSc, Anton Jaklič, PhD, Primož Jan, Borut Lešnik

**SPECIAL INNOVATION AWARD FOR YOUNG COMPANY**

Knez David InDavidual, Zagorje ob Savi

**QuickShoeLace – One Hand Tying Elastic Shoelace with a Ring**

QuickShoeLace is an elastic lace that doesn't need to be tied: you just stretch it and clip it. At one end of the lace is a ring that you just clip onto a metal pivot. All the parts are replaceable and can be disassembled very quickly.

The advantage of this lace is that it can be clipped with just one hand. It is suitable for all generations, as well as those with disabilities or who believe tying laces is a waste of time.

The QuickShoeLace is also a fashion accessory, and personalized laces can be made to order.

Innovator: David Knez



Photo: Knez David InDavidual



## SILVER AWARDS



Photo: Bosio

Bosio  
**Fully Automatic Plant with Isothermal Chamber for Forged Parts - PP-T 8/950**



Photo: INO Brežice

INO Brežice  
**INO Vibration Control System**



Photo: Cerjak

Cerjak  
**Shear Bolt Clutch (ST)**



Photo: Iskra PIO

Iskra PIO  
**Isolator for Weighing Highly Hazardous Raw Material with High Containment Level - OEB 5**



Photo: Domel Holding

Domel Holding  
**VCM for Stick Vacuum Cleaner**



Photo: Isomat

Isomat Mežica  
**Isomat Pre-Fab Prefabricated 3E Application for Advanced Insulation Solutions for the Insulation of Pipes and their Elements**



Photo: Doorson

Doorson  
**Automatic Interior Sliding Doors**



Photo: Kolektor Group

Kolektor Group, Vodenje in upravljanje družb  
**Ensuring of Tightness Using Micro-structuring of Surfaces**



Photo: Esotech

Esotech  
**Waste Water Treatment Plants in Thermal Power Plant Nikola Tesla A**

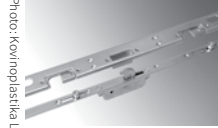

Photo: Kovinoplastika Lož

Kovinoplastika Lož, Stari trg pri Ložu  
**Slam Shut Door Lock**



Photo: GoOpti

GoOpti  
**Intelligentne Transportne Rešitve Innovative Platform Business Model for Penetrating European Markets as a Foundation for Rapid Growth of GoOpti**

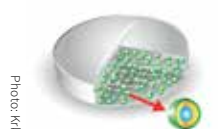

Photo: KRKA

KRKA, Novo mesto  
**Development of Patient-Friendly Metoprolol Prolonged-Release Formulation for Treating Cardiovascular Diseases**



Photo: HIDRIA AET

HIDRIA AET Družba za proizvodnjo vžignih sistemov in elektronike  
**SSDM (Solid State Driver Module)**



Photo: L-TEK Elektronika

L-TEK Elektronika  
**FlyNest**

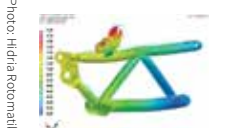

Photo: Hidria Rotomatika

Hidria Rotomatika, podružnica Koper, PE Hidria Mototec  
**Simulation of Welding of Motorcycle Frames**



Photo: MAHLE Letrika

MAHLE Letrika, Proizvodnja električne in elektronske opreme za motorna vozila  
**Alternator With Innovative Cooling for Long Service Life**



Photo: Impol 2000

Impol 2000  
**Impol Extreme**



Photo: Radeče Papir Nova

Radeče Papir Nova  
**New Fluorescent Security Protection in Security Paper**



Photo: Roto Group

Roto Group  
**Sea kayak Buran 488**



Photo: Sastela

Sastela  
IT Pharma  
**Fast and Simple Way to Order Cakes**



Photo: SIJ Metal Ravne

SIJ Metal Ravne, Ravne na Koroškem  
**SITHERM S630 R**



Photo: Splošna bolnišnica Slovenj Gradec

Splošna bolnišnica Slovenj Gradec /  
General Hospital Slovenj Gradec  
**»Implementing Telemedicine for Higher  
Quality of Life and Healthier Society«  
and »EXODIAB - for the Integrated  
Treatment of Diabetic Patient«**



Photo: Steklarna Hrastnik

Steklarna Hrastnik  
**Application of Three Different  
Technologies for the Production of  
Glass Products on Single Furnace**



Photo: Stork

Stork  
**Natural Ice Cream STORK**



Photo: TPV

TPV  
**Innovative Automated Guided Vehicle  
Optimatik 160**



**we are innovative**

We look for better solutions and different approaches, we strive to create new ways of doing things.

**we are reliable**

Our partners' trust is important to us. We always keep our promises and deliver top quality products and services.

**we are global**

We are wherever you need us. Always ready to deliver exactly what you want, exactly when you need it.



**Elrad Group**

Your partner of choice for development and production of electronic components.



*gorenje projekt*

# Customer tailored solutions

[www.gorenje-projekt.com](http://www.gorenje-projekt.com)

## Intralogistics systems

- Complete solutions for intralogistics from idea to realisation, including basic and detailed design, manufacturing, installation, and control systems.
- Design and supply of separate devices like conveyors, shuttles, storage/retrieval machines, various cranes, and their integration into third party systems.
- In-house software solutions for material flow control and warehouse management provide flexibility for customer specific requirements.



## Construction engineering

- Construction: production facilities, commercial and residential buildings, public buildings.
- Infrastructure: water supply, sewage disposal, waste water treatment facilities.

## Energetics

- Combined heat and power plants based on bubbling fluidized bed combustion technology suitable for combustion of solid renewable and sustainable fuels such as RDF, sewage sludge.
- Equipment for small and medium hydroelectric plants: design, production and erection of hydro-mechanical equipment including locks and weirs, dam equipment, steel linings, penstocks.



# Premium Quality Industrial Cutting Tools

**TRO Cutting Tools - developing and supplying superior machine knives and blades to industry.**



Based in the town of Prevalje in northern Slovenia, TRO Cutting Tools, which celebrates its 90th anniversary this year, is a strategic supplier of industrial machine knives and blades to eminent European companies. Its products are used by both the manufacturing and recycling sectors, and are built into machinery used in the plastics, metal, timber, wood and paper industries.

TRO manufactures are sold in 55 countries worldwide. Western Europe and the USA currently account for the major portion of production; this year, however, some important steps have been taken to place its products and penetrate markets in Russia and the Middle East.

Consequent to its in-house research and product development, TRO's clients don't consider it a mere supplier, but also a consultant and provider of technical support in the design and manufacture of new machinery and equipment.

Employing 150 people, the company acquired a new strategic owner in September 2013, whose objective is the long-term development of the company.

## **Forever One Step Ahead**

TRO is investing over five million euros in the business over the 2014 to 2018 period. A large part of this investment is being made into cutting tools for mechanical and thermal processing and grinding in order to enhance the products' resilience and cutting ability as

well as durability and resistance to wear and tear. Aware that different industries have different requirements in relation to the blades they need, various materials and coatings are developed and tested to ascertain the most suitable for individual purposes and processes, as well as to ensure a prolonged product life.

New equipment and improved working conditions have resulted in ever-higher quality products and increased capacities. Constant investment in personnel education and training, as well as the acquisition of know-how is significantly contributing to the company's ability to accept new development challenges and meet the demands of a constantly evolving market.

## **Process Optimisation**

TRO Cutting Tools strives to achieve ongoing process development and improvement in order to ensure the manufacture of excellent products, and – with that – customer satisfaction and loyalty.

The watchword is quality, a notion which is acknowledged, shared, performed and maintained by employees at every level. Quality is also subject to clearly predetermined requirements and standards – through quality control and maintenance of the ISO 9001 standard. Ongoing training and upskilling of personnel to undertake management, development, manufacture and sales, also facilitates product evolution as well as customisation in accordance with the individual needs and requirements of the customer.



## **Quality First**

In addition to guaranteeing excellence through traceability, TRO products are manufactured from premium-quality European tool steel, which gives them an advantage over lower-price competition. Our satisfied clients remain loyal, many for more than 20 years. For these reasons, the company has been able to record fifteen percent annual growth in revenues over recent years, and anticipates this will continue into the future.

## Konica Minolta reduces costs and optimises IT support with ISL Online

Konica Minolta Business Solutions Europe has been using ISL Online remote desktop software since 2010 and solves 80% of all technical issues through ISL Online.



KONICA MINOLTA

*"Apart from the efficient performance, the ISL Online support team has won Konica Minolta's trust with their fast reaction time and highly efficient support."*

**Joerg Sitzlack, Konica Minolta.**

### Benefits

- One remote support software for all help desk operators across Europe
- Decreased administration operations
- 80% of all technical issues solved through ISL Light
- Full customisation of remote desktop control software
- Centralised management of all users through Microsoft Active Directory, NetIQ eDirectory, OpenLDAP or RADIUS
- Branded website for remote support:  
[remotesupport.konicaminolta.eu](http://remotesupport.konicaminolta.eu)

### Private Cloud Solution

- Three Corporate Server Licenses installed on three servers in Konica Minolta's own data centre in Germany
- Unlimited number of users, workstations or simultaneous active connections
- Faster connection, almost 100% fault tolerance and active backup

### About ISL Online

ISL Online is a pioneer in the remote desktop support industry. Since 2003, ISL Online has been providing remote control software via cloud or on-premises to IT professionals and helpdesk technicians in more than 100 countries.

# Environmental Projects in South Africa

**»The Republic of South Africa (RAS) is an exciting market not only because of its size but also because of its open economy and membership in BRICKS association,« says Janez Pergar, Honorary Consul of RSA in Slovenia.**

*Andreja Šalamun*

**Currently, Slovene companies in RSA have a strong market presence in pharmacy, information technologies, energy and particularly environmental projects, but there is potential for many more economic niches.**

In 2016 Slovenia's exports to RSA fell just short of 38 million euros and are currently experiencing a steady increase, according to the Centre for International Business (CEMP) at the Chamber of Commerce and Industry of Slovenia (CCIS). In 2016 the bilateral trade between the countries exceeded 54 million euros, while in the period from January to May 2017 it reached almost 21 million euros.

According to CEMP, Slovenia's main exports to RSA include pharmaceutical products, automotive parts and metallurgical parts, while it mainly imports raw materials for the steel industry, wine, and citrus fruits.

Despite a great geographical distance, the economic ties between the countries are growing stronger, according to Janez Pergar, Honorary Consul of RSA in Slovenia. »These data cover only the trading of goods, while we have no solid data re services; the extent of these we can only estimate,« says Pergar, adding that in his opinion trade in services is also

quite considerable. »Particularly in the area of information technologies and tourism,« explains Pergar. »A lot of the trade between our countries is conducted via third countries, particularly in the case of the automotive industry.«

## JAR As a Spring Board

»The Republic of South Africa is an exciting market. Its population exceeds 50 million, it has an open economy and is a member of BRICKS association which makes it a good springboard for the whole of sub-Saharan Africa,« says Pergar.

Along with pharmaceuticals, information technologies, energy and particularly environmental products, Pergar projects future opportunities in waste management, water supply and drainage.

## Aircraft for Aerial Surveillance of Endangered Species

Pipistrel has been trading with RSA for over 15 years. »RSA is an important market for us. RSA is among the richest countries on the African continent and has large potential. The existing market for small aircraft has a big developmental potential,« says a representative of Pipistrel. Pipistrel is present in RSA with their whole range of products. »The demand includes a wide range of different aircraft, from gliders, suitable for leisure activity, to powerful motor aircraft, suitable for businesses,« says Taja Boscarol of public relations at Pipistrel.

According to Taja Boscarol, »wealthy individuals prefer to travel by plane as this allows fast travel over large distances and dangerous terrain where there are no asphalt roads. As the number of these clients is growing so is the demand for flight schools and aero clubs, which represent a growing client base for Pipistrel. Our main clients, however, are various government and non-government organizations; e.g., animal protection organizations. One of our clients is an organization engaged in prevention of poaching.



Photo: Pipistrel

Our aircraft are fast and silent and used for aerial surveillance of endangered animal species.«

50 Pipistrel aircraft currently fly in RSA and there is huge potential for growth, says the Ajdovščina-based company. »Thanks to new serial production of the 4-seater Panthera, Pipistrel will be able to satisfy the growing demand for this plane.«

Krka has been present in RSA for several decades

The pharmaceutical company Krka is another Slovene company trading with RSA. »RSA is an important African market for Krka and has been for several decades. We sell prescription pharmaceutical as well as non-prescription products. Due to RSA markets' local specifics, Krka operates through local partners. In the future we intend to obtain marketing authorization for several new products and so enlarge our product portfolio,« according to the public relations division at Krka.

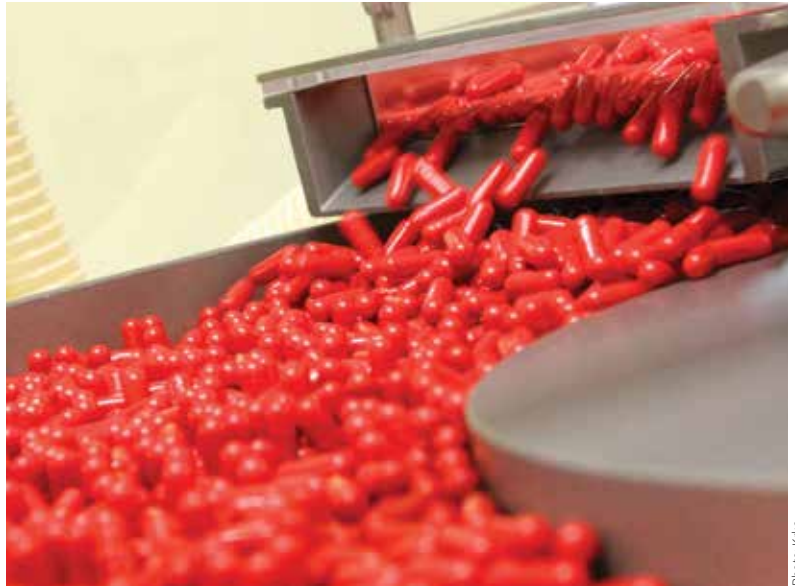

Photo: Krka

## CABLEX GROUP

[www.cablex.si](http://www.cablex.si)

**Cablex Group is a system developer, producer and supplier of wire harnesses, plastic and silicone components, and a variety of electro mechanical subassemblies. It employs over 2,500 people in nine production units in Slovenia, Serbia, Bosnia-Herzegovina, Poland, Turkey and China.**

**Cablex Group has almost 30 years of experience in classical crimp and IDC technology and manufactures products for leading manufacturers in the white goods, automotive and other industry sectors.**

**With the consistent quality of its products, its productivity and its flexibility, Cablex Group continues to demonstrate its capability to quickly respond to its customers' needs and their ever-stricter requirements. Cablex promptly follows the worldwide technological trends and invests every year in new, modern equipment. Financial stability and pro-active involvement of all stakeholders fostering further development and growth of the whole Cablex Group are the basis for a longterm partnership with all our customers.**

# DAPZ d.o.o.

**TOOL AND DIE MAKING COMPANY**

DAPZ d.o.o.  
Veliki Otok 44c, 6230 Postojna, Slovenija  
tel. +386-5-720-24-80 | +386-5-994-95-43  
fax: +386-5-720-24-81  
Email: info@dapz.si

DAPZ d.o.o. – private owned company established in 1997, specialists for TOOL and DIE making, with 85% turnover in automotive industry.

## **Core business:**

- tools for car lightning industry (optics, aesthetic parts, technically demanding parts)
- tools for technical parts (high preciseness)



## **We provide comprehensive toolmaking services:**

- we assist in product development
- we make tool designs
- we produce tools
- we test the tools
- we measure metal components and plastic samples

## **Modern equipped with the following machines:**

- Tool dimensions up to 1000x700mm, 6T
- 4x cnc milling machine 3 axis – up to 50.000rpm
- 2x cnc milling machine 5 axis – up to 80.000rpm
- 2x cnc EDM machine
- 2x cnc WIRE EDM machine
- 1x coordinate measurement machine
- +other conventional machines

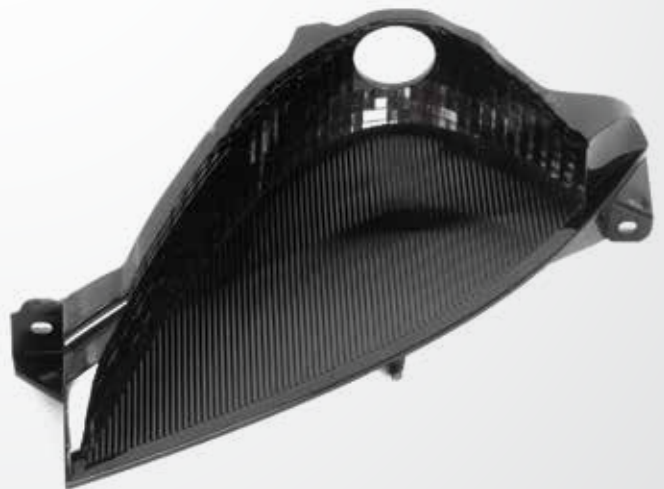

[www.dapz.si](http://www.dapz.si)





E-mail address: [info@sibiz.eu](mailto:info@sibiz.eu)  
Telephone number: +386 1 200 92 00  
[www.sibiz.eu/en](http://www.sibiz.eu/en)

# *A safe haven for a successful business in the centre of Europe.*

Slovenia, successfully representing itself on the world stage (despite its size) and with significant potential for further development, is a country of great opportunities for business and investment. The main share of the country's GDP lies in the export of high-tech products to the countries of the European Union and Russia. Small Slovenian companies and scientific research institutes work for some of the world's most famous companies.

In addition, Slovenia is a country full of natural wonders, excellent sports and travel opportunities, a quiet rhythm of life and a high level of personal and public safety, with great public education and health services.

The country's convenient location and excellent transport infrastructure makes it easy to transport goods to other countries of the European Union and across the world. Opening the company's head office in Slovenia allows unhindered access to the 500 million strong European Union market. SIBIZ business services Ltd., a member of the Chamber for the Promotion of Direct Foreign Investment and Internationalization is the leading company in its market segment, holds the highest AAA rating and is legally authorized to register a new company directly in the office.



**General Director of SIBIZ business service Ltd., Jan Poniž**

Granting this status and authority to perform registrations and other procedures is a recognition and confirmation of the quality of our work by the Government of the Republic of Slovenia and the Ministry of Public Administration of the

Republic of Slovenia. This status provides high-quality services for our current and future clients and allows us to expand the range of services offered to our clients in one place - our office.

With our help you can successfully develop your business and invest in Slovenia. We are happy to provide support with following services:

- legal, tax, accounting, and investment consulting;
- professional comprehensive assistance for your business development in Slovenia;
- obtaining licenses and certificates;
- assistance in obtaining financial resources from EU and Slovenian funds;
- company registration, assistance in obtaining all the necessary documents;
- real estate operations support;
- commercial real estate for your investments;
- business partners in Slovenia;
- translation and interpretation services in various language combinations;
- Slovene language courses;
- common domestic issues support in Slovenia;
- introductory trips in Slovenia;
- accounting support;
- administrative services.

**The company SIBIZ offers services in the field of legal, tax, immigration, investment and business consulting.**

**If you are interested in opening or transferring business to the European Union, selecting and supporting investments, please contact us!**

E-mail address: [info@sibiz.eu](mailto:info@sibiz.eu)  
Telephone number: +386 1 200 92 00  
[www.sibiz.eu/en](http://www.sibiz.eu/en)



Photo: Inicijativa Start:up Slovenija

# A Cryptocurrency Offering Raises 10 Million Dollars in Less Than 5 Minutes

**Around 100 startup companies emerge in Slovenia every year. Slovenia hosted the biggest and most influential startup conference in the Alps-Adriatic regions. The interest of international corporations is growing.**

*Barbara Perko*

**Viberate sold all 120 million crypto tokens, worth over 10 million dollars in 4 minutes and 42 seconds.**

Viberate achieved its goal in less than five minutes: it sold all 120 million crypto tokens, worth over 10 million dollars in 4 minutes and 42 seconds. Viberate's goal is to create a global marketplace for the live music industry by creating a platform for matching musicians with event organizers. Matej Gregorič, director and a founder of Viberate, expressed delight at this wide support for their vision, which is changing the world of live music.

Viberate is one among the highly successful startups in Slovenia. Stanislava Vabšek of the Initiative Start:up Slovenia estimates that around 100 startups emerge in Slovenia every year. »It is difficult to say which are the most successful startups in the country. These entrepreneurial ventures typically develop a viable business model around an innovative product,

service, process or platform. The level of risk is very high. Today you are on the top of the world, tomorrow you go bankrupt,« says Vabšek.

Currently, the most successful among the 67 startups that received a startup incentive from the Slovene Enterprise Fund include Viar, Datafy.it, Borza terjatev, Varlock, Simarie, Beeping, NERVteh. Very successful are also Iconomy, Cashila, Lake Coloring, Zemanta, Facility, Celtra etc. »The current frenzy around crypto companies and initial coin offering has reached a fever pitch. These companies are very successful in cryptocurrency crowdfunding and currently give the impression that they are absolutely booming,« adds Vabšek.

**The Most Influential Startup Conference in the Alps-Adriatic Region**

Startups are expected to continue flourishing. The Initiative Start:up Slovenia anticipates the growing importance of the PODIM conference. »Slovenia organized the most influential startup conference in the Alps-Adriatic region. PODIM is an effective platform for investing into the most promising startups in the region, as well as for actively connecting startups and corporations. This will continue,« foresees Vabšek.

A Pan-European fund expected to be set up by the end of 2017 will make some 250,000 euros available to young companies with great global potential.

The Slovene Enterprise Fund will continue to provide financial support to startup companies. »SEF provides financial instruments, while Initiative Start:up Slovenia, together with the ecosystem partners, offers consultants and mentors,« says Vabšek. Presentations of foreign startup accelerators and funds in Slovenia will also continue.

**Who Are Foreign Companies to Turn to?**

Foreign companies need to link with stakeholders in the Slovene startup ecosystem. Information is provided by Initiative Start:up Slovenia, Business Angels of Slovenia and ABC Accelerator Slovenia.







Photo: Depositphotos

# ESOT-INVEST

*Company for construction of cooling systems and systems for assessment and treatment of all types of water*

*Cooling systems and water treatment plants*

 **ESOT-INVEST d.o.o.**  
 Kersnikova 21  
 3000 Celje, Slovenija  
 [www.esot-invest.net](http://www.esot-invest.net)  
 [esot-invest@esot.net](mailto:esot-invest@esot.net)  
 ++ 386 (0)3 42 56 350



**PRODUCTION OF COOLING SYSTEMS**

*Our own know-how.  
Custom made solutions*

*We made care of entire process -  
from project to design to start up*

**WASTEWATERS (MUNICIPAL AND INDUSTRIAL)**

*Automatic WWTP  
Complete water treatment from  
inlet to outlet*



**INDUSTRIAL WATERS**

*RO - reverse osmosis  
Ultrafiltration  
UV disinfection  
Neutralization*



**DRINKING WATER**

*For waterworks  
For Cities*



# rd rujzdesign

made in slovenia



TANGIBLE QUALITY



SPECIAL SOLUTIONS



FROM THE TIMES OF IRON



SPECIAL DESIGN

USEFUL, SMART AND  
PATENTED



# Reduce time to market with the local PCB supplier

**By promoting innovation and investments in automation, AKA PCB has become one of the leading European manufacturers of printed circuit boards. In the 52 years of their existence, they have specialised in producing single-sided printed circuit boards.**

Their printed circuit boards are sold on the domestic market, as well as on foreign ones, where they export 90 percent of their production. The company's main markets are the countries of the European Union. They sell their printed circuit boards to manufacturers of household appliances, automotive electronics, lighting industry, telecommunications, medical equipment, and other technologies.



## Using automation to achieve high quality and productivity

The company maintains its market position and competitiveness by constantly upgrading its production process and increasing automation, which allows them to achieve high quality and productivity. The entire business process is supported by the ISO 9001 quality management system and the ISO 14001 environmental management system. Most of their procedures and materials comply with the UL laboratory-based surveillance and all their products and procedures are compliant with the RoHS and REACH Directives and originate from the EU.



AKA PCB follows technological innovations in the field of printed circuit board production. Their production is supported by CAD-CAM technology and is compatible with CAD systems for constructing printed circuit boards in the GERBER or DXF format. The company has its own tool development and production, which contributes to a faster, more rational and more flexible mass production.

## The company's strategic location enables rapid delivery across Europe

The main advantages of the company AKA PCB are high-quality, timeliness, flexibility, good responsiveness, and high levels of expertise. They are able to compete with the western and European manufacturers due to their location in Central Europe, which allows them to deliver their goods to all European countries in a short period of time.

As they are aware that the production and technology of printed circuit boards are closely intertwined, their highly-qualified experts offer clients help and counselling in the design stage. The company is large enough to produce large series of products and, at the same time, small enough to be able to adapt to the client's needs. AKA PCB is a highly innovative company with excellent staff, capable of quickly responding to clients and fulfilling their needs.



## A large percentage of income goes to investments

By developing their technology and expanding their production capacities, the company has become the only European manufacturer able to provide large XXL printed circuit boards, which are currently in high demand, especially among manufacturers of LED lighting technologies.

AKA PCB will continue to invest in the automation of their production and HR development, which will enable them to quickly respond to the customers' wishes and needs and deliver high-quality printed circuit boards in a short period of time.

**AKA PCB d.o.o.**  
**Rožna dolina 54, SI-4248 Lesce**  
**Tel.: +386 4 537 87 00**  
**aka@aka-pcb.si**  
**www.aka-pcb.si**





# Slovene Products Taking Your Breath Away

**Slovene businessmen and businesswomen constantly use their knowledge to develop breath-taking products. Their innovative approaches convince the best in numerous fields.**

*Compiled by Barbara Perko*

## **Niche Products for the World's Best Athletes**

During the past year, Sandiline presented a complete line of technical clothes for standup paddleboarding (SUP) under the brand name Standout. SUP is one of the fastest growing sports in the world, so the company decided to invest the knowledge and experience it has accumulated in the past thirty years to this promising field.

Sandiline's primary field is technical clothing for water sports. In addition to manufacturing a line of proprietary products, Sandiline and Standout also work with Adidas, Prada, Helly Hansen, and Prijon. The company often works on special projects creating gear for fire fighters, police, civilian protection and military personnel.

Sandiline manufactures many special items that are not made by its larger competitors. The company's competitive advantage lies in its ability to adapt products to the specific desires and needs of end users. With its niche products, Sandiline reaches the

**Sandiline often works on special projects creating gear for fire fighter, police, civilian protection and military personnel.**



best athletes in the world and other sophisticated customers.

Currently, Sandiline is focusing on SUP products, new canyoning suits, and novelties for the sailing segment. The company also aims to enter the marine kayaking segment. It is open to proposals and collaboration in all areas, but its main goal is to successfully penetrate the US market.

**Alpina Develops a Niche Line of Heated Footwear**

The Alpina Company, based in Žiri, Slovenia, is moving in the direction of niche footwear. This year it is rounding out its collection with double heated hunting shoes, lined with a waterproof and air-cushion membrane to be sold mainly in the UK and Scandinavia. The heating system is also built into Alpina’s backcountry hiking shoes that are suitable for low temperatures. The target markets for these products are the US, Russia, and Scandinavian countries.

Currently Alpina is developing a new product group of light hiking shoes, a segment in which it has not been present before. Alpina is collaborating on the development of this line with the studio Design Development under the leadership of Claudio Franco of the Italian company Asola. The first products in this line will come on the market as part of the 2019 collection. The company is also working on the development of diabetic shoes.

»The goal of the new development projects is not only to consolidate Alpina’s position on regional markets but also to increase sales abroad where we see a great opportunity for the growth and development of the brand,« stated an Alpina representative. The company is seeking new business contacts in Italy, Germany, Austria, Finland, and Russia. In its fashion footwear segment, it is looking for new partners, particularly in the Scandinavian countries.

**Innovative Slovene Ice Cream**

The Organika + company and the ecological vegetable ice cream brand Indy&Pippa are presenting innovative new ice cream to the European market. The ice



Photo: Alpina

cream contains no soya, added sugar, milk, or gluten. Indy&Pippa carries an Eco-Certification, meaning that all ingredients are produced in an ecological manner, without pesticides, artificial fertilizers, or genetically modified organisms. Only the best quality ingredients go into Indy&Pippa ice cream, and the packaging is also biodegradable.

Indy&Pippa ice cream was first sold in Slovenia, then across the border in Croatia. Now it is available in Saudi Arabia as it meets halal dietary standards. In the coming year, the company plans to expand production capacities, enabling them to enter new markets.



Photo: Organika +

Printed on the recycled paper Viprint, 80 g, by VIPAP VIDEMARŠKO, d. d.

Exceptional



Photo: Stem

**Stem: With Their Machines You Can Make a Seven-Fold Reduction in Costs**

Some of the world's most prestigious companies – including ABB, Voith, Siemens, Škoda, Linde, Bobcat and Mahle – use shotblasting machines manufactured by Stem. Energy saving is becoming increasingly important, especially in industrial plants where energy savings and the resulting increased competitiveness of the company can be very high. An example is the replacement of compressed-air shotblasting technology with much more efficient turbine shotblasting machines. Stem has developed a high-pressure turbine blasting system for wagons, which yields a seven-fold reduction in energy consumption. The process is fully automated. This technology enables faster sandblasting, contributes to lower energy consumption and greater automation possibilities. STEM is already gaining new orders for this innovative system.

Stem also provides specialist machinery for the automotive and aircraft industries, as well as the most technologically demanding peening processes. For example, Škoda's vehicle production lines have more than twenty sandblasting machines made by Stem, while Russia's largest railway wagon manufacturer has ten; the list of users and applications is indeed extensive.



We process materials such as different types of steel, hardened and tempered piston rods, cast parts, stainless steel (INOX), aluminium, bronze, plastics, etc.

We specialise in the processing of complicated medium-sized modules and we are known for the accomplishment of required tolerances up to 0.01mm. Our tolerances are monitored in a state-of-the-art measuring room, which is equipped with various measuring instruments and other measuring equipment, including a 3D CNC coordinate measuring machine. Our parts are used in a range of hydraulic components, conveyors, draw-works, cranes, lifting platforms, ironworks, transport facilities, hydropower stations, etc.

**Foreign representation**

Foreign markets: Germany, Austria

**Cooperation with German companies**

Our high quality and professionalism have made a name for our company abroad, since most of our customers are based in Germany and Austria. Our long-term goal is based on our flexibility, quality, perseverance, continuous training of our employees and modernisation of our machinery and software portfolio.



[www.ferolin.com](http://www.ferolin.com)

**Field of business**

We are a family business with more than 40 years of experience and nearly 50 committed and motivated employees.

Currently, we are operating approx. 16 CNC machines manufactured by Japanese top manufacturer MAZAK as well as machines from other manufacturers. We dispose of CNC lathes of different sizes (diameter of the turning head from 250 to 550mm), various vertical and horizontal CNC machining centres and state-of-the-art 5-axis CNC machines. Our equipment enables us to deliver a high productivity and to remain competitive on a highly demanding European market.

**Production range/services**

In addition to mechanical machining using the CNC machines mentioned above, we also offer our customers mechanical processing with traditional machining centres, pounding, cutting and welding of various components as well as assembly, mounting and painting of individual modules and much more.



# Searching for products and services?

Find over 6.000 companies, their  
products and services, or brands.

[www.sloexport.si](http://www.sloexport.si)

Connecting you to reliable companies from Slovenia.

## Relevant

We connect customers with relevant Slovenian companies and businesses quickly and effortlessly.

## High accuracy

Our database is updated and refreshed daily. We take great effort to provide users with the highest data accuracy.

## Guarantee

Only registered companies are presented. Search with confidence and assurance



## Certificate EXCELLENT SME

The Chamber of Commerce and Industry of Slovenia issues certificates for SMEs to outline to potential business partners and all customers if a company is safe to do business with. It supports companies by showing to other stakeholders (creditors, partners or customers) that they can be trusted.

## Summary

The main purposes of the certificate, coinciding with EU directives, are to support successful small and medium enterprises, to secure business relations, to exchange best practices and increase market transparency. Additionally, it helps customers and business partners to decrease their financial risks when buying products/services or signing business agreements. The certificate enables local and international business partners to verify company's existence with a legitimate web address, and most importantly credit worthiness. By using the certificate, potential and existing partners and customers can differentiate between successful and less successful companies in the cyber world and in a real business date-to-date operations. The mandatory elements to obtain the annual certification is a credit report and daily monitoring from COFACE Slovenia. In parallel, the SafeSigned™ website technology prevents the «Excellent SME Slovenia» quality seal to be copied and used on any other website.

## Main results

Until now, 2140 companies were certified as Excellent SMEs, including 795 in Slovenia, 733 in Serbia, 219 in Montenegro, 179 in Romania, 94 in Hungary, 86 in Macedonia, 20 in Croatia, 12 in Bulgaria and 2 in Slovakia. The actual numbers change daily and can be checked on the following address <http://www.excellentsme.com/certified-companies.php>



**MORE THAN 1000  
DIFFERENT  
PRODUCTS IN STOCK**

**Are you looking for technical standard and standardised parts, or specialist solutions for the most varied of applications?**

We can offer you a comprehensive and cross-industry range of plastic and hybrid (metal-plastic) technical products.

# Plastic injection moulding

Your reliable, flexible, and innovative partner for technical products where it matters!

- Competence and over 35 years' experience in the production of technical plastic goods in the injection moulding process. •



# KOVINOPLASTIKA LOŽ

— Since 1954 —



ARX



ALVEUS



KOVINOtools

Research

Development

Engineering

Process building

Production

We are reliable partner from the development of the products to the serial production on our tools.

Our core production technologies are

**STAMPING • DEEP DRAWING • DIE CASTING • INJECTION MOULDING • MACHINING • TOOLMAKING  
PART FINALIZATION • WELDING • HEAT TREATMENT • GALVANIC SURFACE PROTECTION • ASSEMBLING • WASHING**

## Building fittings

State-of-the-art building fittings:

PVC and wood windows  
(completing solutions for alu options)

- Tilt and turn building fittings systems,
- Shutter fittings,
- Sliding fittings,
- Door fittings.

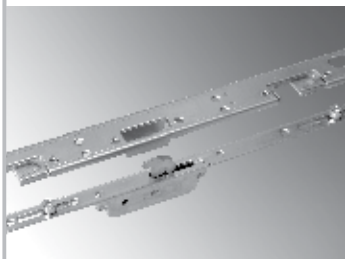

## Kitchen sinks

Professional and home use:

- Kitchen sinks,
- Kitchen equipment,
- Gastronome pans and containers,
- Cookers,
- Cooker hoods,
- Systems for separate waste collection.



## Tools

Production of:

- Progressive stamping tools,
- Transfer stamping tools,
- Deep drawing tools,
- Die casting tools for Zn alloys, for automotive, fittings and kitchen industry.



## Components

Components for:

- Automotive,
- Sport,
- Electrical and electronic,
- Other products made of Zn alloys, polymers, steel and stainless steel shet metal.





## Slovenia – Your Next Filming Location?

**Global brands Audi, BMW and Jaguar, as well as Pepsi, Nivea and McDonald's, have all chosen Slovenia to shoot their promotional videos. This past summer, Ferrari was on location on the Slovene Riviera, while Fiat was shooting in central Slovenia with the American actor Chuck Norris.**

*Andreja Lončar, Photos: Viba film*

**High-quality services, great locations and low costs. These are the reasons why so many choose to make their promotional videos in Slovenia.**

Filming in Slovenia is particularly popular with vehicle manufacturers. »We believe they are drawn by great locations that have not been overused internationally,« asserts the Ljubljana-based production company, *Viba Film*. »Our local service providers are able to offer a diverse variety of versatile locations, not only in Slovenia, but also in neighbouring Croatia, Austria and Italy.«

The *Viba Film* Studio produces between 200 and 300 promotional videos annually, acting as a technical base as well as providing studios and production facilities, together with costumes and props. Over the past year, *Viba Film* has been involved in projects for Audi, Dacia, Renault, Nissan, Citroën, Jaguar, Volkswagen, Mercedes-Benz and Toyota, together with non-automotive sector clients, such as KFC, Laughing Cow, Ubisoft, and the joint Unicef and Garnier campaign.

### **Why Slovenia?**

Beauty and distinctiveness are very important factors in choosing a film location, in relation to which Slovenia has been gaining a reputation for its pristine nature, as well as diverse scenery and architecture.

»Unique yet accessible locations in unspoiled nature are particularly popular,« remarks *Viba Film*, adding that »Slovenia's current status as a newly discovered exciting film location shall almost certainly be transitory.«

### **Great Locations for a Few Days Filming**

In addition to location, price also plays a major part in choosing where to shoot. Foreign corporate groups choose to make promo videos in Slovenia because of the high quality services they can get at a relatively moderate cost.

The demand for filming in Slovenia has fluctuated over recent years. *Viba Film* observed a sharp increase in its international business between 2000 and 2015, but this has now levelled off. For some, the costs of one- or two-days filming in Slovenia may have become prohibitively high, but, overall, the outlay for crew (travel, accommodation, food) and production services over several days ensure that Slovenia is a great location for longer projects.



**What Are Slovenia's Production Studios Able to Offer?**

- sourcing locations and obtaining necessary permissions for filming
- casting
- provision of technicians, directors and crew
- provision of equipment and related logistics
- scenography, costumes and special effects
- studios and production facilities
- comprehensive local transport and logistics services
- catering
- recording media
- post-production services
- insurance provision and conclusion of mandatory procedures
- travel and accommodation



**WWW.KGL.SI**

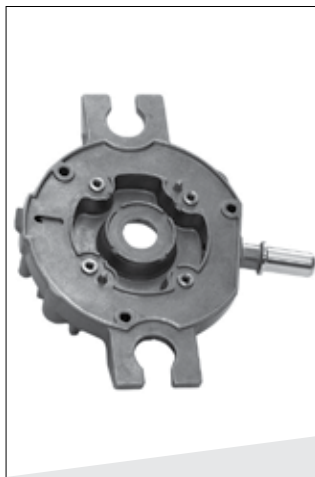

KGL d. o. o. was established in 1985. We supply our products to automotive industry since then. We use aluminium (die casting and gravital casting), gray and nodular iron casting and steels. In automotive we are specialized on parts for power trains, engines, steering system and brake systems. Our production is divided on:

**TURNING, MILLING, STAMPING, ASSEMBLING.**

Our production is based on modern and acknowledged machines and equipment such as Mori, Seiki, Mazak, Index, Hunyadi, Daewoo, etc.



**LAND PLOTS FOR BUSINESS / INDUSTRIAL DEVELOPMENT**

## ŽELODNİK

**Land plot for a modern business park, suitable for a wide range of activities.**

- Ideal for business, manufacturing, crafts, retail business, logistics etc.
- Close to the airport, Ljubljana and two European motorway corridors.
- Total measurement of the zone: 64 ha.

**LOCATION:** Želodnik, Domžale, Slovenia

**NET FLOOR AREA:** NA

**PLOT AREA:** 314,339 m<sup>2</sup>



## SEŽANA

**Land plot with superb strategic position and direct proximity to ports, railways, highway, Italy and Croatia, suitable for large logistic operators.**

- The plot located in the as-yet undeveloped industrial zone in Sežana.
- Close to the local road, railway, motorway exit, Port of Trieste (13 km) and Port of Koper (35 km Port of Koper (35 km)).

**LOCATION:** Sežana, Slovenia

**NET FLOOR AREA:** NA

**PLOT AREA:** 334,297 m<sup>2</sup>



The pictures are symbolic.

**LAND PLOTS FOR TOURISM / RESIDENTIAL / BUSINESS DEVELOPMENT**

## VILHARJEVA

**Easily accessible property fully equipped with all essential infrastructure.**

- Situated next to the main railway in Ljubljana, capital of Slovenia.
- Suitable for two developments with a total measurement of 42,846 m<sup>2</sup>.
- Communal fee (EUR 1.5 million) is included in the price.

**LOCATION:** Ljubljana, Slovenia

**NET FLOOR AREA:** 3,437,5 m<sup>2</sup>

**PLOT AREA:** 10,244 m<sup>2</sup>



©REAL Engineering d.o.o.

## ARGOLINA

**Land plot ideal for tourism-commercial-residential development with a promenade running along the coast.**

- Majestic views of the bay of Koper.
- Located in a tourist area and areas of green space.
- Communal fee (EUR 2.7 million) is included in the price.

**LOCATION:** Izola, Slovenia

**NET FLOOR AREA:** NA

**PLOT AREA:** 23,703 m<sup>2</sup>



Pictures are symbolic.

## BELGRADE

**Office building with excellent potential for investors.**

- Located in the Novi Beograd business zone.
- Well maintained building with offices (B + G + 4) and a car showroom (B + G + Gallery).
- Parking spaces located in front of the building and in an underground car park.
- Most of the office building is rented and represents opportunity for investors.

**LOCATION:** Belgrade, Serbia

**NET FLOOR AREA:** 12,826.28 m<sup>2</sup>

**PLOT AREA:** 6,606 m<sup>2</sup>



## MARIBORSKO POHORJE

**Hospitality real estate at an attractive Slovenian ski resort.**

- Located in Mariborsko Pohorje where every year FIS skiing is held for women.
- The portfolio consists of: Hotel Arena and Arena Annex, Wellnes Hotel Bolfenk and Apartments, Hotel Videc and Apartma Argolinaents, Residential building Pohorske terase and additional land plots.

**LOCATION:** Maribor, Slovenia

**NET FLOOR AREA:** 17,103 m<sup>2</sup>

**PLOT AREA:** 80,366 m<sup>2</sup>





Laboratory furniture system. Setting new standards by doing things differently.



Service spine systems



Storage



Special purposes cabinets



Fume hoods



Local exhaust systems

The furniture system is designed specifically for use in laboratories, and is made in line with modern standards and guidelines applicable to such equipment in EU.



We are proud to be trusted by numerous institutions and reputable domestic and foreign companies to install our furniture at all stages. We equipped more than 1000 laboratories in 20 countries in Europe and beyond.



Trust the company that has been equipping laboratories for 25 years.

Color your Lab

HEADQUARTERS  
Lab Interior GmbH  
Hirsch-Gereuth Straße 32  
81369 München, Germany

SALES AND PRODUCTION  
Lab Interior d.o.o.  
Zagrebška cesta 22  
2000 Maribor, Slovenia

PHONE +386 2 614 33 33  
FAX +386 2 614 33 20  
WEB [www.labinterior.de](http://www.labinterior.de)  
EMAIL [info@labinterior.de](mailto:info@labinterior.de)

We are looking for potential business partners!

# container

## www.container.si

Container, d.o.o.  
Bežigrajska cesta 6, 3000 Celje, Slovenia  
T: +386 (0)3 42 63 246, F: +386 (0)3 42 63 276  
E: info@container.si



Logistics container

### Meeting Customer Expectations for Over Forty Years

Container d.o.o.'s tradition is built on the metal-working foundries that became established in the central Slovenian town of Celje at the end of the 19th century. The first containers manufactured in Celje were made for the US market in 1973 by EMO, a renowned company that gave rise to its EMO Konjtejner subsidiary in 1991, the company that became Container d.o.o. in 1998.

Manufacturing standard shipping containers and other metal constructions between 1999 and 2007, Container d.o.o. today fabricates special transport and storage containers for the nuclear power industry and energy sector, as well as the military. In accordance with the various needs and requirements of

its customers, Container manufactures a wide variety of products including bulk containers, half-height containers, open top containers, insulated containers and containers for transporting radioactive waste.

The four decades of tradition in this business is based on the original manufacture of standard shipping containers; over the past 15 years, however, the company's production

engineering has embraced increasingly complex forms. In-house development and testing facilities, teamwork and well-organised processes, create the basis of the company's flexibility as well as the provision of integrated solutions. Through a study of the requirement, Container will devise and build a solution.

Based on longstanding experience, a high level of knowledge and know-how, together with modern facilities and equipment, Container d.o.o. provides solutions to operators in the transport and logistics sectors, as well as in the fields of energy and ecology. It also manufactures bespoke solutions on behalf of clients, including container protection systems, special ADR containers, multimodal housing for equipment, special rail freight applications as well as other metal constructions including vehicle chassis.

### Creative Development at the Company's Core

Container's in-house design and development department engages in the technological preparation of projects and, in co-operation with Slovenian and foreign institutes, faculties and other centres of engineering and logistics know-how and technology, is able to undertake any new development task. In product modelling, Container offers assistance through the preparation of 3D CAD models of containers and pertaining structures, the performance of static and dynamic analyses as well as the testing of container construction.

In order to meet customer requirements, the company implements a development process that leads from concept to finished product, its main characteristics are:

- Short lead times
- Rapid preparation of the 3D CAD model
- Static and dynamic analyses
- Automatic generation of plans (working sketches, NC programs)
- Prototyping
- Testing of prototypes and optimisation for serial production
- Creation of welding machines for serial production
- Individual and small-scale production
- The potential for problems in relation to the manufacture of special containers is reduced through the provision of consultancy and advice, as well as in-house development and production in direct accordance with the modelled product and finalised order.
- Technical certification is prepared for special containers, including a detailed construction design and operational documentation, all of which is verified and vindicated through the provision of 3D model and collision tests.

### Custom-Built Durability

Container d.o.o. forever aims to meet every specific need through its manufacture of high quality products, encompassing standard and special containers as well as bespoke containers of every conceivable type. The company also manufactures related metal constructions and equipment, as well as provides storage and logistics solutions for its products.

All of Container's projects are prepared by experienced designers using 3D CAD software, which, in turn, facilitates computer aided manufacture (CAM). Optimal design, vigorously controlled manufacture and tested construction, ensure that manufactures are durable and long lasting. The number and complexity of Container's development projects rise year on year as well as the number of satisfied customers.



Offshore container



Container for nuclear waste

# 40 years of engineering



SINCE  
1982

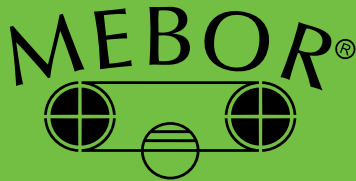

WOODWORKING  
MACHINERY



[www.mebor.eu](http://www.mebor.eu)

## COMPLETE SOLUTIONS FOR THE SAWMILLING INDUSTRY

**MEBOR** has been designing, developing and producing **sawmilling machinery since 1982**. The company supplies complete **solutions for sawmills**, therefore all machines needed for the primary sawing of wood, joined into **complete sawing lines**. Moreover, these are completely adjusted to the needs of each customer. The scope of Mebor products covers the needs for sawmilling of small softwoods logs and up to large hardwood logs.

Mebor has been one of the fastest growing companies in Slovenia. It has been among companies worldwide with the most **intense innovation** and presenting of **new products** in the field of **sawmilling**.

### The Mebor Know-How

Sawmilling experience of its team gave Mebor the most important perspective -

**understanding the needs** and problems **of sawmills**. The team consists of **experts** from all walks of **machine designing**, mechanical and electrical engineering, hydraulics, safety and electronic automation. Mebor is the **worldwide leader** in wide blade **horizontal band saws**, both in terms of **advanced technology** and number of units produced per year. Some Mebor innovations have had a **direct influence on the sawmilling industry**.

Every year, Mebor invests the vast majority of funds into **research and development**, as well as in increasing of manufacturing capacity.

### Mebor worldwide presence

Mebor has been one of the fastest growing companies in Slovenia. Today Mebor machines are running in more than **50 countries worldwide**. The machines are recognised by their **automation, speed** and **reliability**.

### The Mebor Quality Guarantee.

As Mebor is a family company, **quality** is their **personal goal**. The company is using the latest manufacturing technologies and tested **components** from **renowned** global manufacturers. Inspections of **quality** and **performance guarantee** the quality of every Mebor machine. Mebor is certified by ISO 9001:2015 Management System



**MEBOR** d.o.o.  
Češnjica 48 B  
4228 Železniki  
Slovenia

**Produce more at lower costs!**

**tel.:** +386 4 510 32 00 **fax.:** +386 4 510 32 01 **e-mail:** mebor@mebor.si



Are you looking for a market research  
on optical industry in Slovenia?

Are you looking for a new business partner  
or you are interested in acquisitions?

**Contact CCIS Analytics, your trusted partner in Slovenia for:**

- in-depth analysis of a specific sector
- reports on financial performance of a particular industry
- identifying drivers of sector performance with a forward looking estimates

Contact us at: [analitika@gzs.si](mailto:analitika@gzs.si) or +386 1 5898 170  
and we will send you a competitive bid in 3 working days.

# EXPERTISE, DILLIGENCE, ETHICS



## BUSINESS WORLD AT A GLANCE

### Our services. Your trip to success

- Individual meetings made just for your company
- Organization of events for various target groups
- Seminars, workshops and business delegations
- Expertize in several fields
- Consultation
- Finding selected contacts and new business partners
- Strengthen your export



**Expertise**

**Flexibility**

**Innovation**

**Partnership  
and sustainable  
relationship**

**Cooperation**

# Index

- A**  
 A1 98  
 ABB 142  
 ABC Accelerator  
   Slovenia 137  
 Adidas 5, 140  
 Adient 47  
 Adiko banka 98  
 Adria Home 46  
 Adria Mobil 46, 51  
 Aereform 123  
 Agitavit Solutions 98  
 Airbus 43  
 Akrapovič 42  
 Alcon 101  
 Alfa Romeo 43  
 Alfastreet Marine  
   46, 47  
 Alkaloid 79  
 Alpina 141  
 Alstom 5, 44, 78, 83  
 Amazon 45  
 AMC 77  
 Amica 51  
 Antibiotice 79  
 Aprilia 42  
 ArvinMeritor 45  
 Asko 51  
 Asola 141  
 Aston Martin 42  
 Audi 5, 43, 44, 45, 53,  
   79, 146  
 Axalta 98  
 Axo Light 53
- B**  
 Bacardi Martini 53  
 BAT 52  
 Bayerische  
   Versorgungskammer  
   98  
 Bayer Pharma 79  
 Beeping 136  
 Belupo 79  
 Bentley 43, 45  
 Bitzer 44  
 BMW 5, 42, 44, 45, 47,  
   54, 79, 146  
 Bobcat 142  
 Boehler Bleche 78  
 Boeing 43  
 Bombardier 5, 44, 52  
 Borza terjatev 136  
 Bosch 44, 45, 53, 77  
 Bosh 79  
 Bosio 78, 127  
 Bosnalijek 79  
 BSH Hišni aparati 123  
 BTC Logistics 90  
 Business Angels of  
   Slovenia 137
- C**  
 Can-Am 43  
 Cashila 136  
 Caterpillar 44
- Celtra 136  
 Cerjak 127  
 CETIS 123  
 Chrysler 44  
 Citroën 44, 46, 146  
 Cleangrad 101  
 Continental 44
- D**  
 Dacia 45, 146  
 Daimler 44, 45, 47  
 Danfoss 78  
 Danfoss Trata 54, 124  
 DARS 91  
 Datafy.it 136  
 Delamaris 67, 68  
 Delo 97  
 Deutsche Bahn 44  
 Deutsche Telekom  
   5, 98  
 Domel 53, 54, 127  
 Don Don 66, 67  
 Doorson 127  
 DSM 101  
 Dubai Silicon Oasis  
   97  
 Ducati 42, 44
- E**  
 Elan 51, 53, 122, 124  
 Electrolux 5, 53, 77  
 E-mart 97  
 Emirates 97  
 EPPS 91  
 Esotech 127  
 ETI 124
- F**  
 Facility 136  
 Ferrari 42, 45, 146  
 Ferročrtalič 43  
 Fiat 44, 46, 146  
 Fissler 78  
 Ford 48, 78
- G**  
 Gaggenau 5, 51  
 Garnier 146  
 Gedeon Richter 79  
 General Hospital  
   Slovenj Gradec 128  
 General Motors 45, 78  
 GEN-i 98  
 GKN Driveline 45,  
   47, 48  
 GlaxoSmithKline 101  
 Global Coatings  
   Group 76  
 GoOpti 97, 127  
 Gorenje 51, 52, 77,  
   124  
 GossenMetrawatt  
   GMC 83  
 Gram 51  
 Great Wall 44  
 Grundfoss 44
- H**  
 Haier 51  
 Hansgrohe 52  
 Heineken 53  
 Helios 76, 77  
 Helly Hansen 140  
 Hemofarm 79  
 Henkel 79  
 Hennessy 53  
 Hexal 79  
 Hidria 44, 98  
 HIDRIA AET 127  
 Hidria Rotomatika  
   127  
 Hilti 98  
 Honda 42  
 HP 98  
 Husqvarna 54, 77  
 Hyundai 45
- I**  
 IBM 98  
 Iconomy 136  
 Impol 76, 79, 80, 127  
 InDavidual 126  
 Initiative Start:up  
   Slovenia 137  
 INO Brežice 127  
 InterContinental  
   Ljubljana 59, 60  
 Iskra 83  
 Iskraemeco 84, 125  
 Iskra PIO 78, 79, 127  
 Isomat 127  
 Istrabenz Turizem 62  
 IT Pharma 128
- J**  
 Jaguar 44, 45, 48, 146  
 JLR 45  
 Jtekt 45
- K**  
 Kansai Altan 77  
 Kansai Paint 77  
 Kärcher 5, 54  
 Kawasaki 42  
 Kerrock 52  
 KFC 146  
 Kia 45  
 King Fisher 53  
 Koenigsegg 43  
 Kolektor 98, 127  
 Kolpa 52  
 Kovinoplastika Lož  
   53, 79, 127  
 Kovis 43  
 Krka 72, 73, 79, 98,  
   125, 127, 133  
 KTM 42, 44, 77
- L**  
 Lake Coloring 136  
 Land Rover 45, 48  
 Larsen & Toubro 78  
 Laughing Cow 146  
 Lavorwash 54
- Ledinek Engineering  
   125  
 Lek 72, 73, 79, 126  
 Lemförder & ZF  
   Lenksysteme 45  
 Leroy Marlin 53  
 Liebherr 51, 77  
 LifeClass 62  
 Lightyears 53  
 Linde 142  
 Lotrič Metrology 84  
 L-TEK Elektronika 127  
 LTH Castings 44  
 Luka Koper 88, 89
- M**  
 Magna 53, 79  
 Mahle 142  
 Mahepa 45  
 MAHLE Letrika 127  
 Mayo Clinic 97  
 McDonald's 146  
 McLaren 42, 77  
 Mentek 90  
 Mercedes-Benz 42,  
   44, 48, 54, 79, 146  
 Metrel 83  
 Michelin 59  
 Mikropis 97  
 Microsoft 98  
 Miele 51  
 MINI 43  
 Mithra  
   Pharmaceutical 101  
 Mora 52  
 MotoGP 42  
 Muller 79
- N**  
 NASA 45  
 NERVteh 136  
 Nidec 44  
 Nike 52  
 NIL 97, 98  
 Nilfisk 54  
 Nissan 43, 146  
 Nivea 146  
 Nobilia 53  
 Northern Lighting 53  
 Novartis 73, 101  
 Novartis NEVA 79
- O**  
 Octapharma 101  
 Opel 44  
 Orange Business  
   Services 98  
 Organika+ 141  
 Orrefors 51
- P**  
 Palo Alto 98  
 Paloma 55  
 Panasonic 5, 51, 52  
 Pepsi 146  
 Perutnina Ptuj 68  
 Peugeot 44, 45, 79  
 Pfizer 101
- Philips 53  
 Pipistrel 45, 132  
 Pirnar 52  
 Pivka Perutninarstvo  
   67, 68  
 Pliva 79  
 Podravka Group 66,  
   67  
 Porsche 42, 44, 45,  
   53, 77  
 Pošta Slovenije 91  
 Postojnska Jama 60  
 Prada 5, 140  
 Prijon 140  
 Privo Hotel 51
- Q**  
 Qatar Airlines 97
- R**  
 Radeče Papir Nova  
   127  
 Rational AG 54  
 RC eNeM Novi  
   Material 124  
 Renault 43, 44, 45,  
   48, 79, 146  
 Revoz 48  
 Rico 97  
 Robers 53  
 Robotina 50  
 Rogaška 52  
 Roto Group 128  
 Rowenta 53  
 RZB 53
- S**  
 Sainsbury's 53  
 Salutas 79  
 Sandiline 140  
 Sandoz 79, 98, 101  
 Sanolabor 79  
 Sastela 128  
 Sava Hotels & Resorts  
   59, 61  
 Schneider Electric 83  
 Seat 44  
 Sharp 51  
 Siemens 44, 45, 78,  
   83, 142  
 SIJ Acroni 126  
 SIJ Metal Ravne 128  
 Simarie 136  
 Skaza 54  
 Škoda 44, 45, 78, 142  
 Slatnar 122  
 Slovene Enterprise  
   Fund 136, 137  
 Smart 48  
 SNCB 44  
 Sony 52  
 Špica 90  
 SRC 98  
 Stadler 44  
 Steklarna Hrastnik  
   52, 128  
 Stem 142
- Stihl 54  
 Stork 128  
 Styler 96  
 Suzuki 42  
 Slovenske železnice  
   90
- T**  
 Talum 76, 78  
 TATA 97  
 Telecom Italia 98  
 Telekom Slovenije 98  
 TEM Čatež 51  
 Terme Krka 62, 63  
 Termikel 51  
 Tesla 44  
 Teva 79  
 The Pullman Hotel 51  
 Thyssenkrupp 78  
 TKK 80  
 Toring Turbine 101  
 Toyota 146  
 TPV 47, 128  
 Turna 51, 52
- U**  
 Uber 45  
 Ubisoft 146  
 Unicef 146  
 Unior 45
- V**  
 Varlock 136  
 Velux 98  
 Vestel 51  
 Viar 136  
 Viba Film 146, 147  
 Viberate 136  
 Villeroy&Boch 53  
 VMware 97, 98  
 Voith 142  
 Volkswagen 43, 44,  
   45, 146  
 Volvo 44, 45, 47, 48  
 Vossloh 44
- W**  
 Wabco 44  
 Waterford 52  
 WMF 77  
 World Bank 98
- X**  
 XAL 53  
 XTurn 51
- Y**  
 Yamaha 42, 43  
 Yanmar 44
- Z**  
 Zemanta 136  
 Zepter 77  
 ZF 45  
 Žito 66, 67  
 Zoetis 101  
 ZZI 90

# CALENDAR OF FAIRS AND FESTIVALS 2017/18

## CELJE FAIR

18th November	<b>3rd WINE, PROSCIUTTO AND SALAMI FESTIVAL</b>
1st – 3rd December	<b>10th sLOVErotika</b> , Erotic Show
17th January	<b>2nd CAREER FAIR MOJEDELO.COM and 5th FESTIVAL OF EDUCATION</b> Co-organiser: Styria digital marketplaces d.o.o.
17th and 18th March	<b>23rd FLORA</b> Everything for your Garden, Home and Surroundings <b>14th ALTERMED</b> A Healthy Way of Living <b>41st APISLOVENIA</b> Beekeeping Days in Celje <b>17th WEDDING</b> Everything for a Wedding <b>3rd KULINART</b> Food and Drink Festival <b>2nd COFFEE FESTIVAL SLOVENIA</b>
18th – 21st April	<b>1st TECHEXPO CELJE</b> , International Technology Fair Energetics Terotech – Industrial Maintenance and Cleaning Automation, Mechatronics and Industrial Electronics Woodworking Machinery and Tools, Intermediate Goods, Forestry Technology
16th June	<b>3rd FESTIVAL OF BEER, BURGERS AND CHILI</b>
11th – 16th September	<b>51st MOS INTERNATIONAL TRADE AND BUSINESS FAIR</b> MOS – Construction and Home Renovation MOS – Craft and Industry Equipment and Materials MOS – Camping and Caravanning, Tourism and Food MOS – Business Services and Business Opportunities Abroad MOS – General Consumption Products
18th – 20th October	<b>2nd FEEL THE FUTURE</b> Innovative Digital Solutions
17th November	<b>4th WINE, PROSCIUTTO AND SALAMI FESTIVAL</b>
30th November – 2nd December	<b>11th sLOVErotika</b> , Erotic Show

*The organiser reserves the right to change dates*

Celjski sejem d.d.  
Dečkova cesta 1, 3000 Celje, Slovenia  
T: +386 3 54 33 000 | F: +386 3 54 19 164  
E: info@ce-sejem.si



www.ce-sejem.si 

AKRAPOVIČ D.O.O., MALO HUDO 8A, 1295 IVANČNA BORICA, SLOVENIA

# DRIVING THE PULSE OF TIME

OUR CUTTING-EDGE TECHNOLOGY ENABLES US TO CREATE INNOVATIVE FORMS AND DESIGNS,  
CRAFTING EMOTIONS INTO EVEN THE SMALLEST DETAILS TO MAKE EVERYONE NOTICE.

 **AKRAPOVIČ**